



Electrical &  
Electronics

EUROFINS ELECTRICAL TESTING SERVICE (SHANGHAI) CO., LTD.

# EMC TEST- REPORT

**TEST REPORT NUMBER: EFSH25090011-IE-01-E01-A2**



Electrical &  
Electronics

Eurofins Electrical Testing Service (Shanghai) Co., Ltd.  
Building 18, No.2168 Chenhang Highway, Minhang District,  
Shanghai, China

Phone: +86-21-36202800  
Fax: +86-21-61819180  
Page 1 of 106

## TABLE OF CONTENTS

### 1 Contents

|          |  |            |
|----------|--|------------|
| <b>1</b> | <b>Contents</b>  | <b>2</b>   |
| <b>2</b> | <b>General Information</b>                                     | <b>4</b>   |
| 2.1      | Notes  | 4          |
| 2.2      | Testing laboratory   | 5          |
| 2.3      | Details of approval holder                                     | 6          |
| 2.4      | Application details  | 6          |
| 2.5      | EUT information  | 6          |
| 2.6      | Test standards   | 7          |
| <b>3</b> | <b>Technical test</b>  | <b>8</b>   |
| 3.1      | Summary of test results  | 8          |
| 3.2      | Test environment   | 8          |
| 3.3      | Test mode  | 8          |
| 3.4      | Measurement decision rule                                      | 8          |
| 3.5      | Test equipment utilized  | 9          |
| 3.6      | Test results   | 10         |
| <b>4</b> | <b>Emission Test</b>   | <b>11</b>  |
| 4.1      | Conducted Emission   | 11         |
| 4.2      | Disturbance power  | 22         |
| 4.3      | Harmonic Current Emissions                                     | 28         |
| 4.4      | Voltage Changes, Voltage Fluctuations and Flicker              | 41         |
| <b>5</b> | <b>Immunity Test</b>   | <b>43</b>  |
| 5.1      | Performance Criteria Description in Clause 6 of EN IEC 55014-2 | 43         |
| 5.2      | Classification of apparatus                                    | 43         |
| 5.3      | ESD  | 44         |
| 5.4      | Electrical Fast Transients                                     | 45         |
| 5.5      | Surge Immunity   | 46         |
| 5.6      | Injected currents (RF continues conducted)                     | 47         |
| 5.7      | Voltage dips and Interruption                                  | 48         |
| <b>6</b> | <b>Test Setup Photos</b>                                       | <b>49</b>  |
| <b>7</b> | <b>EUT Photos</b>  | <b>52</b>  |
| <b>8</b> | <b>Amendment 1</b>   | <b>106</b> |

---

Test Report No.: EFSH25090011-IE-01-E01-A2

---

Eurofins Electrical Testing Service (Shanghai) Co., Ltd.  
Building 18, No.2168 Chenhang Highway, Minhang District, Shanghai, China

## 2 General Information

### 2.1 Notes

The results of this test report relate exclusively to the item tested as specified in chapter “Description of test item” and are not transferable to any other test items.

Eurofins Electrical Testing Service (Shanghai) Co., Ltd. is not responsible for any generalisations and conclusions drawn from this report. Any modification of the test item can lead to invalidity of test results and this test report may therefore be not applicable to the modified test item.

The test report may only be reproduced or published in full. Reproducing or publishing extracts of the report requires the prior written approval of the Eurofins Electrical Testing Service (Shanghai) Co., Ltd.

This document is subject to the General Terms and Conditions and the Testing and Certification System of Eurofins Electrical Testing Service (Shanghai) Co., Ltd. available on request or accessible at

<https://www.eurofins.cn/consumer-product-testing/industries/electrical-electronics/general-terms/>

#### Operator:

| 2026-01-28 |               | Crystal Liu/ Project Engineer | <i>Crystal Liu</i> |
|------------|---------------|-------------------------------|--------------------|
| Date       | Eurofins-Lab. | Name / Title                  | Signature          |

#### Technical responsibility for area of testing:

| 2026-01-28 |          | Kalsi Chen / Supervisor | <i>Kalsi Chen</i> |
|------------|----------|-------------------------|-------------------|
| Date       | Eurofins | Name / Title            | Signature         |

Test Report No.: EFSH25090011-IE-01-E01-A2

Eurofins Electrical Testing Service (Shanghai) Co., Ltd.  
Building 18, No.2168 Chenhang Highway, Minhang District, Shanghai, China

## 2.2 Testing laboratory

### **Eurofins Electrical Testing Service (Shanghai) Co., Ltd.**

Building 18, No.2168 Chenhang Highway, Minhang District, Shanghai, China

Telephone : +86-21-36202800

Telefax : +86-21-61819180

**Test location, where different:**

---

Test Report No.: EFSH25090011-IE-01-E01-A2

---

Eurofins Electrical Testing Service (Shanghai) Co., Ltd.  
Building 18, No.2168 Chenhang Highway, Minhang District, Shanghai, China

### 2.3 Details of approval holder

Name : Ningbo Zhishuai Electrical Appliance Technology Co., Ltd  
 Address : No.158, Shatan Road, Xijie Village, Xinpu Town, Cixi City, Zhejiang Province  
 Telephone : ./.  
 Fax : ./.

### 2.4 Application details

Date of receipt of test item : 2025-09-01  
 Date of test : 2025-09-01 to 2025-09-04  
 Amendment 1 : 2025-12-24 (date of test: 2025-12-23)  
 Amendment 2 : 2026-01-14 (date of test: N/A)

### 2.5 EUT information

Product type : Ice Maker  
 Model name : ZSW-ZB13, ZSW-ZB14, ZSW-ZB15, ZSW-ZB16, ZSW-ZB17  
 Brand name : ./.  
 Serial number : ./.  
 Ratings : AC 220-240V, 50Hz, Class I  
 ZSW-ZB13, ZSW-ZB14: 0,7A, R600a/23g,  
 ZSW-ZB15, ZSW-ZB16, ZSW-ZB17: 0,84A, R290/20g  
 Climate: N, SN, ST, Insulation Blowing Gas: Cyclopentane

Test voltage : AC 230V, 50Hz

Additional information :

The appliances covered by this report are Ice make only for household and indoor use only.



ZSW-ZB16 and ZSW-ZB17 are identical except the model names and appearances.

After review, ZSW-ZB13, ZSW-ZB14, ZSW-ZB15, ZSW-ZB16 were tested and recorded.

See page 106 for Amendment 1 and Amendment 2.

Test Report No.: EFSH25090011-IE-01-E01-A2

Eurofins Electrical Testing Service (Shanghai) Co., Ltd.  
 Building 18, No.2168 Chenhang Highway, Minhang District, Shanghai, China

## Manufacturer:

Name : Ningbo Zhishuai Electrical Appliance Technology Co., Ltd  
Address : No.158, Shatan Road, Xijie Village, Xinpu Town, Cixi City, Zhejiang Province

## 2.6 Test standards

Technical standard :

**EN IEC 55014-1: 2021**

**EN IEC 55014-2: 2021**

**EN IEC 61000-3-2: 2019+A1: 2021+A2: 2024**

**EN 61000-3-3: 2013+A1: 2019+A2: 2021**

### 3 Technical test

#### 3.1 Summary of test results

No deviations from the technical specification(s) were ascertained in the course of the tests performed.



or

The deviations as specified were ascertained in the course of the tests performed.



#### 3.2 Test environment

Temperature : 20 ... 25°C  
Relative humidity content : 30 ... 60%  
Air pressure : 100 ... 103kPa

#### 3.3 Test mode

Operating Mode

#### 3.4 Measurement decision rule

No decision rule is specified by the IEC standard, when comparing the measurement result with the applicable limit according to the specification in that standard. The decisions on conformity are made without applying the measurement uncertainty ("simple acceptance" decision rule, previously known as "accuracy method").

Other:  
CISPR 16-4-2:2011/AMD1:2014 for emission measurements. For immunity testing no decision rule is applicable.

### 3.5 Test equipment utilized

| Measurement Equipment List |   |             |                        |               |
|----------------------------|---|-------------|------------------------|---------------|
| No.                        | Name:                                     | Type:       | Manufacturer:          | Cal due date: |
| 1                          | EMI test receiver                         | ESR3        | R&S                    | 2026-05-18    |
| 2                          | Artificial mains                          | ENV216      | R&S                    | 2026-05-18    |
| 3                          | Click analyser                            | CL55C       | AFJ                    | 2025-08-20    |
| 4                          | Absorbing clamp                           | MDS 21B     | TESEQ                  | 2026-05-18    |
| 5                          | Single phase Harmonics & Flicker analyser | PACS-1      | California Instruments | 2026-05-14    |
| 6                          | AC Power Source                           | 5001ix      | California Instruments | 2026-05-14    |
| 7                          | ESD Gun                                   | NSG 437     | TESEQ                  | 2026-05-18    |
| 8                          | Ultra Compact Simulator                   | UCS 500N7   | EMTEST                 | 2026-05-14    |
| 9                          | Continuous wave simulator                 | CWS500N1    | EMTEST                 | 2026-05-14    |
| 10                         | Coupling/Decoupling Network               | L 801 M2/M3 | Luethi                 | 2026-06-03    |
| 11                         | Attenuator                                | WA59-6-33   | Weinschel              | 2026-05-14    |

---

Test Report No.: EFSH25090011-IE-01-E01-A2

---

Eurofins Electrical Testing Service (Shanghai) Co., Ltd.  
Building 18, No.2168 Chenhang Highway, Minhang District, Shanghai, China

### 3.6 Test results

1st test

test after modification

production test

| Test case   | Subclause  | Required                            | Test passed                         | Test failed              |
|---|--|-------------------------------------|-------------------------------------|--------------------------|
| Conducted Emission                                | Clause 4.3.2 & 4.3.3 of EN IEC 55014-1             | <input checked="" type="checkbox"/> | <input checked="" type="checkbox"/> | <input type="checkbox"/> |
| Disturbance power                                 | Clause 4.3.4 of EN IEC 55014-1                     | <input checked="" type="checkbox"/> | <input checked="" type="checkbox"/> | <input type="checkbox"/> |
| Radiated disturbance                              | Clause 4.3.4 of EN IEC 55014-1                     | <input type="checkbox"/>            | <input type="checkbox"/>            | <input type="checkbox"/> |
| Radiated disturbance (1GHz to 6GHz)               | Clause 4.3.5 of EN IEC 55014-1                     | <input type="checkbox"/>            | <input type="checkbox"/>            | <input type="checkbox"/> |
| Magnetic field (equipment using IPT)              | Clause 4.3.2 of EN IEC 55014-1                     | <input type="checkbox"/>            | <input type="checkbox"/>            | <input type="checkbox"/> |
| Discontinuous disturbance                         | Clause 4.4.2 of EN IEC 55014-1                     | <input type="checkbox"/>            | <input type="checkbox"/>            | <input type="checkbox"/> |
| Harmonic Current Emissions                        | EN IEC 61000-3-2                                   | <input checked="" type="checkbox"/> | <input checked="" type="checkbox"/> | <input type="checkbox"/> |
| Voltage Changes, Voltage Fluctuations and Flicker | EN 61000-3-3                                       | <input checked="" type="checkbox"/> | <input checked="" type="checkbox"/> | <input type="checkbox"/> |
| Electrostatic Discharge                           | Clause 5.1 of EN IEC 55014-2 & IEC 61000-4-2       | <input checked="" type="checkbox"/> | <input checked="" type="checkbox"/> | <input type="checkbox"/> |
| Electrical Fast Transients                        | Clause 5.2 of EN IEC 55014-2 & IEC 61000-4-4       | <input checked="" type="checkbox"/> | <input checked="" type="checkbox"/> | <input type="checkbox"/> |
| Injected currents                                 | Clause 5.3 & 5.4 of EN IEC 55014-2 & IEC 61000-4-6 | <input checked="" type="checkbox"/> | <input checked="" type="checkbox"/> | <input type="checkbox"/> |
| Radio frequency electromagnetic fields            | Clause 5.5 of EN IEC 55014-2 & IEC 61000-4-3       | <input type="checkbox"/>            | <input type="checkbox"/>            | <input type="checkbox"/> |
| Surges  | Clause 5.6 of EN IEC 55014-2 & IEC 61000-4-5       | <input checked="" type="checkbox"/> | <input checked="" type="checkbox"/> | <input type="checkbox"/> |
| Voltage dips                                      | Clause 5.7 of EN IEC 55014-2 & IEC 61000-4-11      | <input checked="" type="checkbox"/> | <input checked="" type="checkbox"/> | <input type="checkbox"/> |

Note 1: The additional margin (0-10dB) was met in the frequency range 200MHz to 300MHz in Disturbance power test (absorbing clamp), and the EUT did not contain any circuit with clock frequency more than 30MHz, so the EUT was compliant with the Radiated disturbance test (300MHz-1GHz) without test (charging condition).

Note 2: The EUT belongs to Category II, so the Radio frequency electromagnetic fields test is not required.

Note 3: The click rate was less than 5, and the click duration was less than 10ms. So it is deemed to comply with Discontinuous disturbance test.

Note 4: Radiated disturbance test in the frequency range from 1 GHz to 6 GHz is not required as the highest clock frequency (F<sub>x</sub>) of EUT is less than 108MHz.

Test Report No.: EFSH25090011-IE-01-E01-A2

Eurofins Electrical Testing Service (Shanghai) Co., Ltd.  
Building 18, No.2168 Chenhang Highway, Minhang District, Shanghai, China

## 4 Emission Test

### 4.1 Conducted Emission

This clause lays down the general requirements for the measurement of disturbance voltage produced at the terminals of apparatus.

#### 4.1.1 Limits

| Frequency range<br>MHz | At mains terminals<br>dB ( $\mu$ V) |               |
|------------------------|-------------------------------------|---------------|
|                        | Quasi-peak Limit                    | Average Limit |
| 0.15 to 0.50           | 66 to 56                            | 59 to 46      |
| 0.50 to 5              | 56                                  | 46            |
| 5 to 30                | 60                                  | 50            |

Note1: The limit decreases linearly with the logarithm of the frequency in the range 0.15 MHz to 30 MHz.

Note2: The lower limit is applicable at the transition frequency.

#### 4.1.2 Measurement procedure

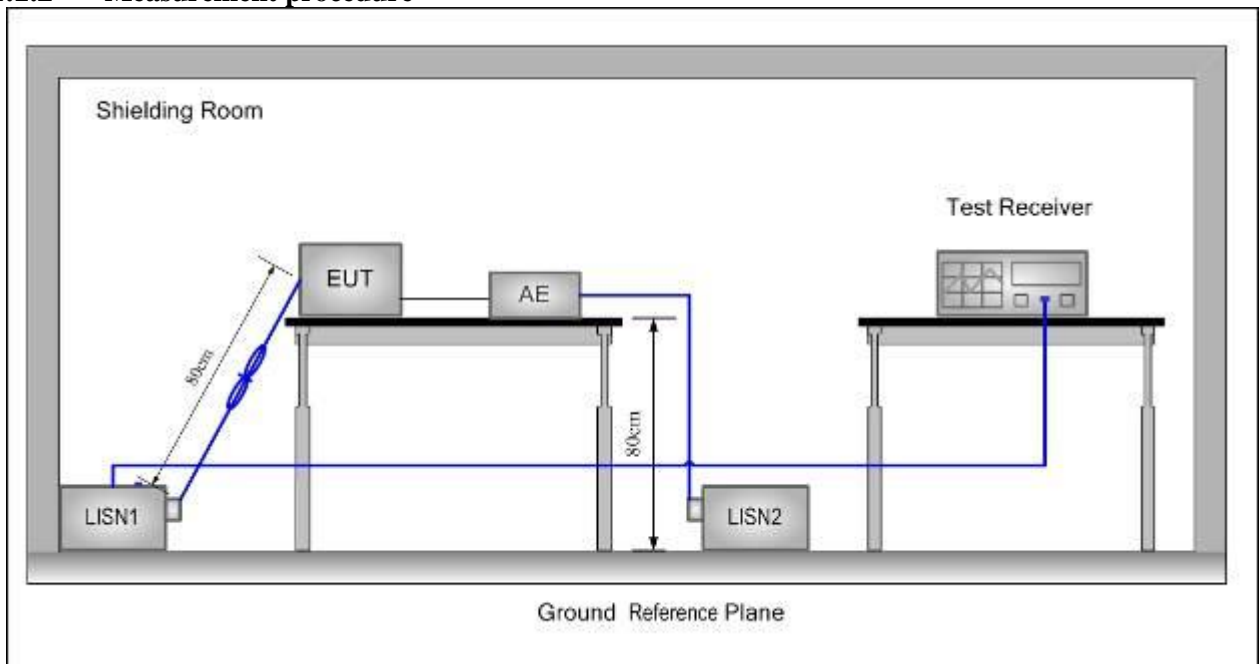

1. The mains terminal disturbance voltage was measured with the EUT in a shielded room.
2. The EUT was connected to AC power source through a LISN (Line Impedance Stabilization Network) which provides a  $(50 \mu\text{H} + 5 \Omega) \parallel 50 \Omega$  linear impedance. The power cables of all other units of the EUT were connected to a second LISN, which was bonded to the ground reference plane in the same way as the LISN for the unit being measured.
3. The tabletop EUT was placed upon a non-metallic table 0.8m above the ground reference plane. And for floor-standing arrangement, the EUT was placed on the horizontal ground reference plane, but separated from metallic contact with the ground reference plane by 0.1m of insulation.

Test Report No.: EFSH25090011-IE-01-E01-A2

Eurofins Electrical Testing Service (Shanghai) Co., Ltd.  
Building 18, No.2168 Chenhang Highway, Minhang District, Shanghai, China

4. Before get the final emission results with quasi-peak(QP) detector and average(AVG) detector, a pre-scan was performed with the peak(PK) and average(AVG) detector to find out the maximum emission data plots of the EUT.

#### 4.1.3 Measurement uncertainty

U<sub>lab(cond)</sub> = 3.3 dB at 95% level of confidence, k=2

#### 4.1.4 Results -Measurement Data

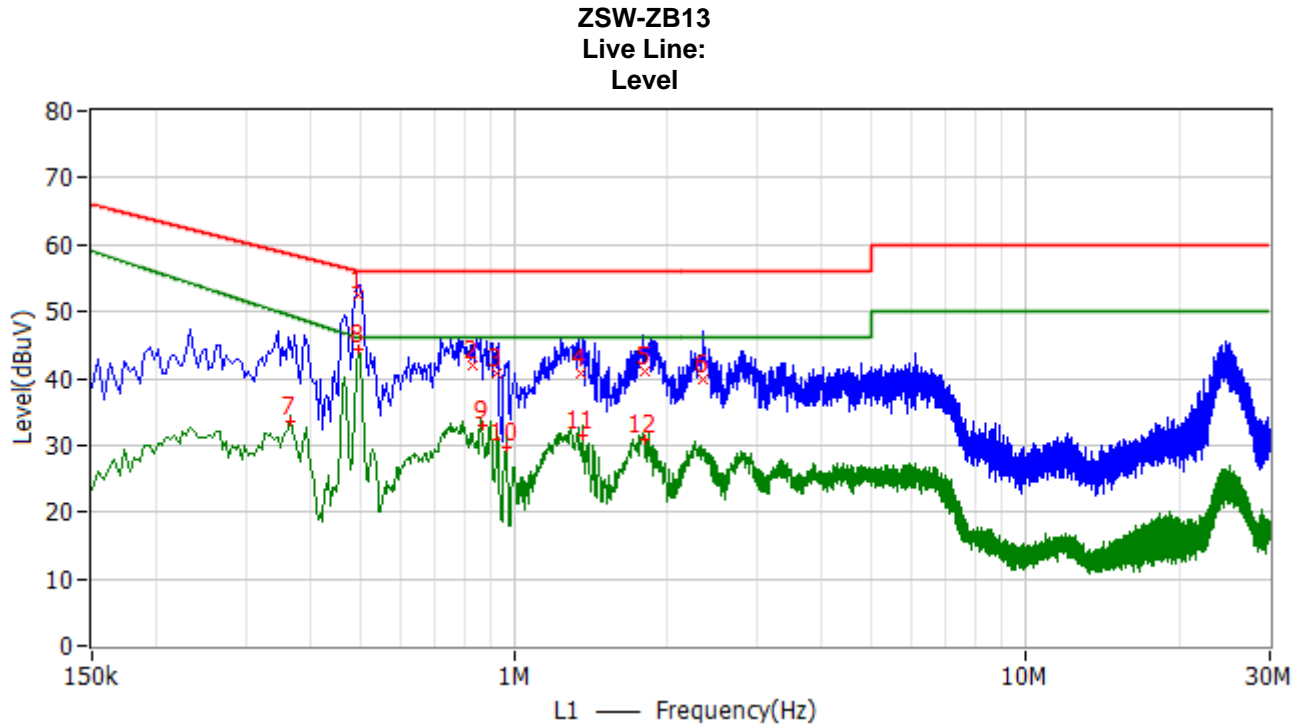

| No. | Frequency   | Limit dBuV | Level dBuV | Delta dB | Factor dB | Detector | Phase |
|-----|-------------|------------|------------|----------|-----------|----------|-------|
| 1   | 498.000 kHz | 56.0       | 52.4       | -3.6     | 10.3      | QP       | L1    |
| 2   | 834.000 kHz | 56.0       | 42.0       | -14.0    | 10.3      | QP       | L1    |
| 3   | 926.000 kHz | 56.0       | 40.8       | -15.2    | 10.3      | QP       | L1    |
| 4   | 1.346 MHz   | 56.0       | 40.6       | -15.4    | 10.3      | QP       | L1    |
| 5   | 1.802 MHz   | 56.0       | 41.0       | -15.0    | 10.5      | QP       | L1    |
| 6   | 2.334 MHz   | 56.0       | 39.8       | -16.2    | 10.6      | QP       | L1    |
| 7   | 366.000 kHz | 49.4       | 33.7       | -15.7    | 10.3      | CAV      | L1    |
| 8   | 498.000 kHz | 46.0       | 44.3       | -1.8     | 10.3      | CAV      | L1    |
| 9   | 866.000 kHz | 46.0       | 32.9       | -13.1    | 10.3      | CAV      | L1    |
| 10  | 966.000 kHz | 46.0       | 29.8       | -16.2    | 10.4      | CAV      | L1    |
| 11  | 1.370 MHz   | 46.0       | 31.4       | -14.6    | 10.3      | CAV      | L1    |
| 12  | 1.802 MHz   | 46.0       | 31.0       | -15.0    | 10.5      | CAV      | L1    |

Neutral Line:  
Level

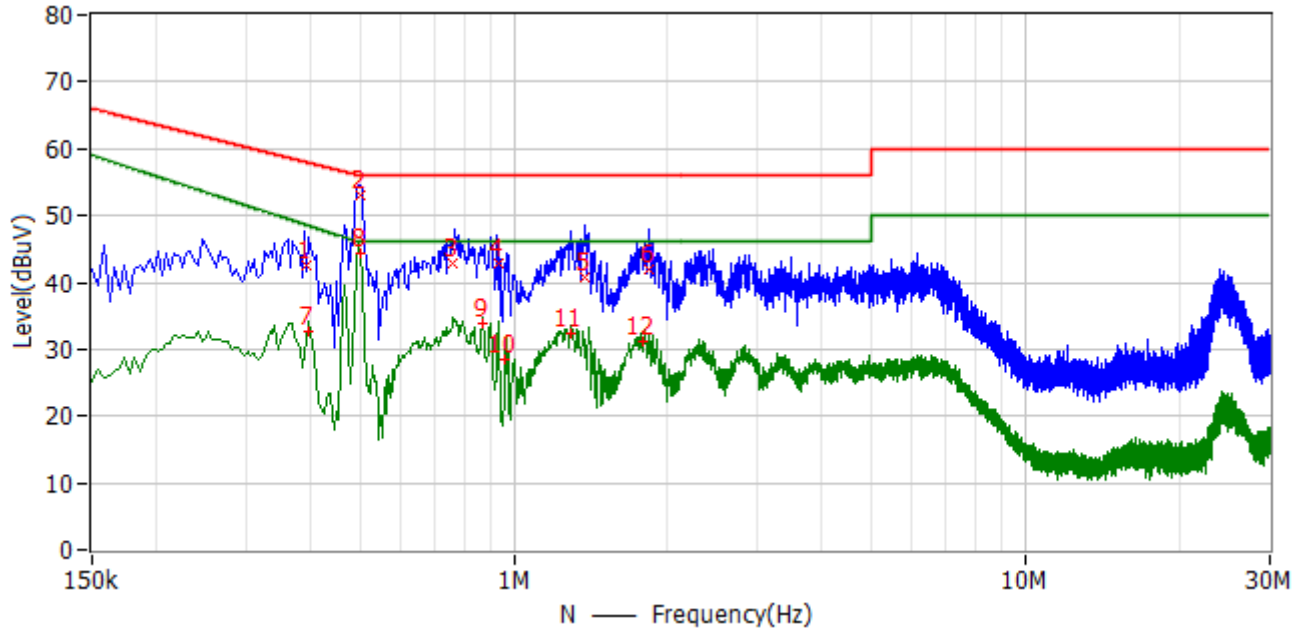

| No. | Frequency   | Limit dBuV | Level dBuV | Delta dB | Factor dB | Detector | Phase |
|-----|-------------|------------|------------|----------|-----------|----------|-------|
| 1   | 394.000 kHz | 58.0       | 42.6       | -15.4    | 10.5      | QP       | N     |
| 2   | 502.000 kHz | 56.0       | 53.1       | -2.9     | 10.3      | QP       | N     |
| 3   | 762.000 kHz | 56.0       | 42.7       | -13.3    | 10.3      | QP       | N     |
| 4   | 938.000 kHz | 56.0       | 42.8       | -13.2    | 10.3      | QP       | N     |
| 5   | 1.378 MHz   | 56.0       | 40.8       | -15.2    | 10.4      | QP       | N     |
| 6   | 1.834 MHz   | 56.0       | 41.9       | -14.1    | 10.4      | QP       | N     |
| 7   | 398.000 kHz | 48.5       | 32.7       | -15.8    | 10.5      | CAV      | N     |
| 8   | 502.000 kHz | 46.0       | 44.3       | -1.7     | 10.3      | CAV      | N     |
| 9   | 866.000 kHz | 46.0       | 34.0       | -12.0    | 10.4      | CAV      | N     |
| 10  | 962.000 kHz | 46.0       | 28.6       | -17.4    | 10.3      | CAV      | N     |
| 11  | 1.294 MHz   | 46.0       | 32.3       | -13.7    | 10.3      | CAV      | N     |
| 12  | 1.794 MHz   | 46.0       | 31.3       | -14.7    | 10.4      | CAV      | N     |

**ZSW-ZB14**  
Live Line:  
Level

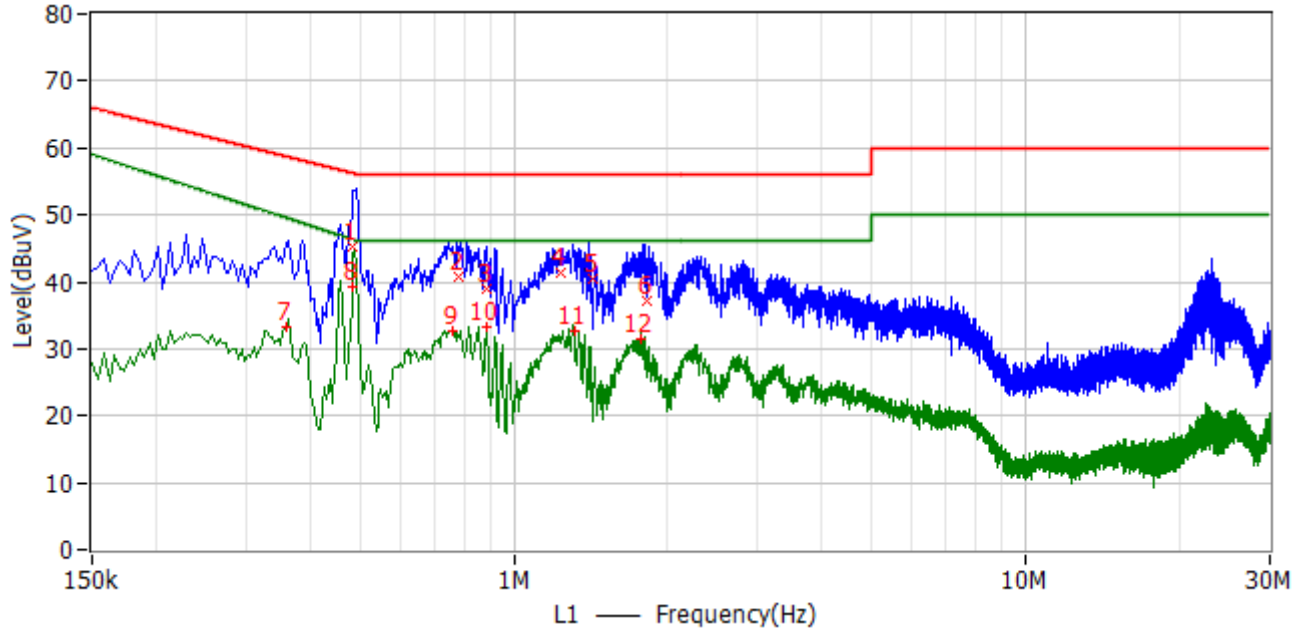

| No. | Frequency   | Limit dBuV | Level dBuV | Delta dB | Factor dB | Detector | Phase |
|-----|-------------|------------|------------|----------|-----------|----------|-------|
| 1   | 486.000 kHz | 56.2       | 45.1       | -11.1    | 10.3      | QP       | L1    |
| 2   | 782.000 kHz | 56.0       | 40.7       | -15.3    | 10.3      | QP       | L1    |
| 3   | 886.000 kHz | 56.0       | 39.0       | -17.0    | 10.3      | QP       | L1    |
| 4   | 1.238 MHz   | 56.0       | 41.2       | -14.8    | 10.4      | QP       | L1    |
| 5   | 1.422 MHz   | 56.0       | 40.5       | -15.5    | 10.3      | QP       | L1    |
| 6   | 1.826 MHz   | 56.0       | 37.3       | -18.7    | 10.5      | QP       | L1    |
| 7   | 358.000 kHz | 49.6       | 33.4       | -16.2    | 10.3      | CAV      | L1    |
| 8   | 482.000 kHz | 46.4       | 39.2       | -7.2     | 10.3      | CAV      | L1    |
| 9   | 758.000 kHz | 46.0       | 32.6       | -13.4    | 10.3      | CAV      | L1    |
| 10  | 882.000 kHz | 46.0       | 33.4       | -12.6    | 10.3      | CAV      | L1    |
| 11  | 1.310 MHz   | 46.0       | 32.8       | -13.2    | 10.3      | CAV      | L1    |
| 12  | 1.766 MHz   | 46.0       | 31.5       | -14.5    | 10.5      | CAV      | L1    |

Neutral Line:  
Level

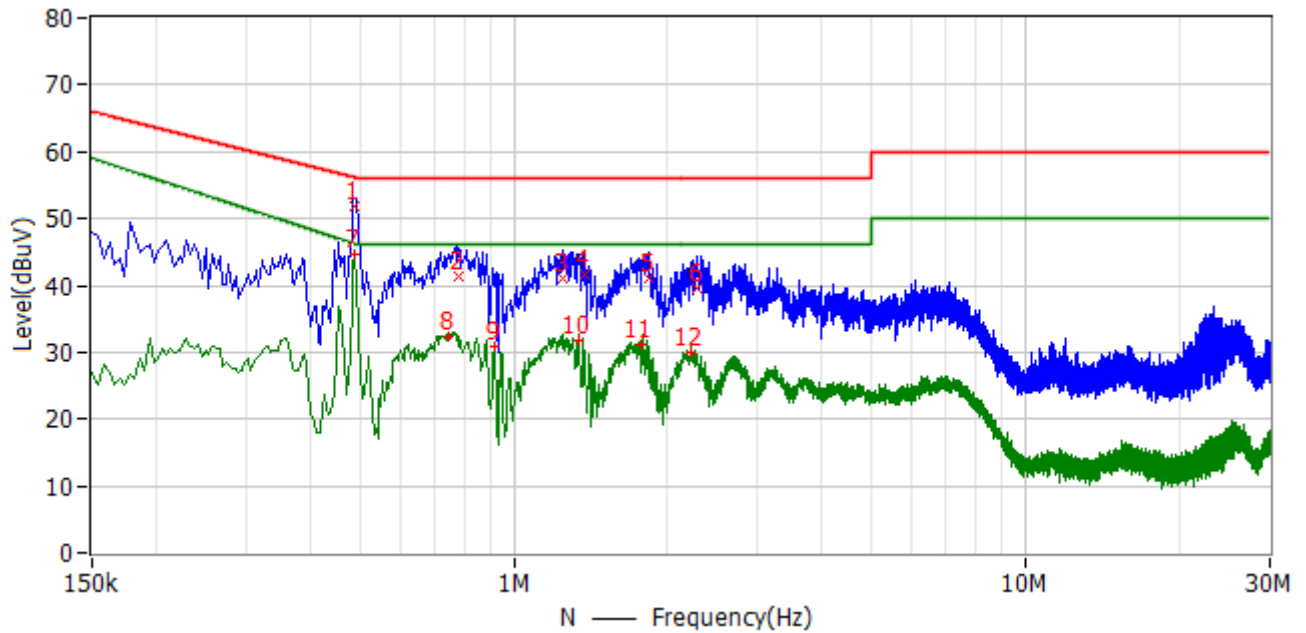

| No. | Frequency   | Limit dBuV | Level dBuV | Delta dB | Factor dB | Detector | Phase |
|-----|-------------|------------|------------|----------|-----------|----------|-------|
| 1   | 490.000 kHz | 56.2       | 51.8       | -4.4     | 10.3      | QP       | N     |
| 2   | 778.000 kHz | 56.0       | 41.3       | -14.7    | 10.4      | QP       | N     |
| 3   | 1.246 MHz   | 56.0       | 40.9       | -15.1    | 10.3      | QP       | N     |
| 4   | 1.378 MHz   | 56.0       | 41.6       | -14.4    | 10.4      | QP       | N     |
| 5   | 1.834 MHz   | 56.0       | 41.0       | -15.0    | 10.4      | QP       | N     |
| 6   | 2.290 MHz   | 56.0       | 39.6       | -16.4    | 10.4      | QP       | N     |
| 7   | 490.000 kHz | 46.2       | 44.6       | -1.6     | 10.3      | CAV      | N     |
| 8   | 746.000 kHz | 46.0       | 32.5       | -13.5    | 10.3      | CAV      | N     |
| 9   | 918.000 kHz | 46.0       | 30.9       | -15.1    | 10.3      | CAV      | N     |
| 10  | 1.338 MHz   | 46.0       | 31.8       | -14.2    | 10.4      | CAV      | N     |
| 11  | 1.770 MHz   | 46.0       | 31.1       | -14.9    | 10.4      | CAV      | N     |
| 12  | 2.226 MHz   | 46.0       | 29.9       | -16.1    | 10.4      | CAV      | N     |

Test Report No.: EFSH25090011-IE-01-E01-A2

Eurofins Electrical Testing Service (Shanghai) Co., Ltd.  
Building 18, No.2168 Chenhang Highway, Minhang District, Shanghai, China

**ZSW-ZB15**  
Live Line:  
Level

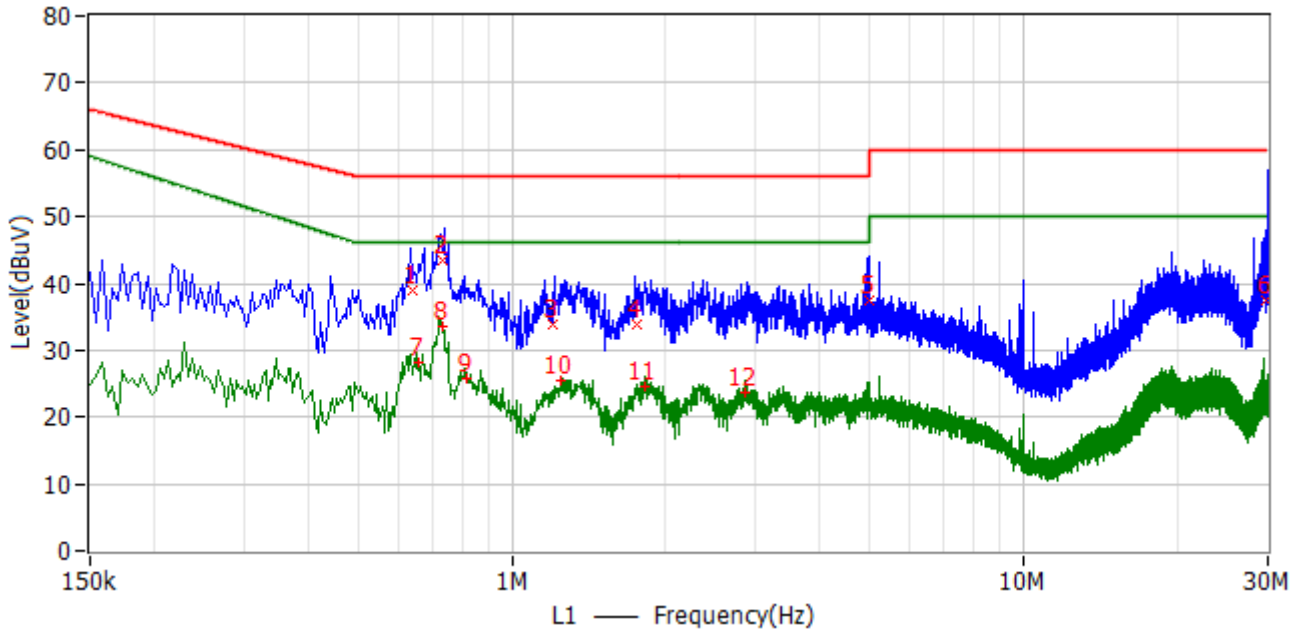

| No. | Frequency   | Limit dBuV | Level dBuV | Delta dB | Factor dB | Detector | Phase |
|-----|-------------|------------|------------|----------|-----------|----------|-------|
| 1   | 642.000 kHz | 56.0       | 39.1       | -16.9    | 10.3      | QP       | L1    |
| 2   | 734.000 kHz | 56.0       | 43.3       | -12.7    | 10.4      | QP       | L1    |
| 3   | 1.202 MHz   | 56.0       | 33.9       | -22.1    | 10.4      | QP       | L1    |
| 4   | 1.750 MHz   | 56.0       | 34.0       | -22.0    | 10.5      | QP       | L1    |
| 5   | 4.982 MHz   | 56.0       | 37.6       | -18.4    | 10.6      | QP       | L1    |
| 6   | 29.806 MHz  | 60.0       | 37.6       | -22.4    | 10.8      | QP       | L1    |
| 7   | 658.000 kHz | 46.0       | 28.1       | -17.9    | 10.3      | CAV      | L1    |
| 8   | 730.000 kHz | 46.0       | 33.6       | -12.4    | 10.4      | CAV      | L1    |
| 9   | 814.000 kHz | 46.0       | 25.8       | -20.2    | 10.3      | CAV      | L1    |
| 10  | 1.242 MHz   | 46.0       | 25.5       | -20.5    | 10.4      | CAV      | L1    |
| 11  | 1.822 MHz   | 46.0       | 24.7       | -21.3    | 10.5      | CAV      | L1    |
| 12  | 2.850 MHz   | 46.0       | 23.8       | -22.2    | 10.6      | CAV      | L1    |

Neutral Line:  
Level

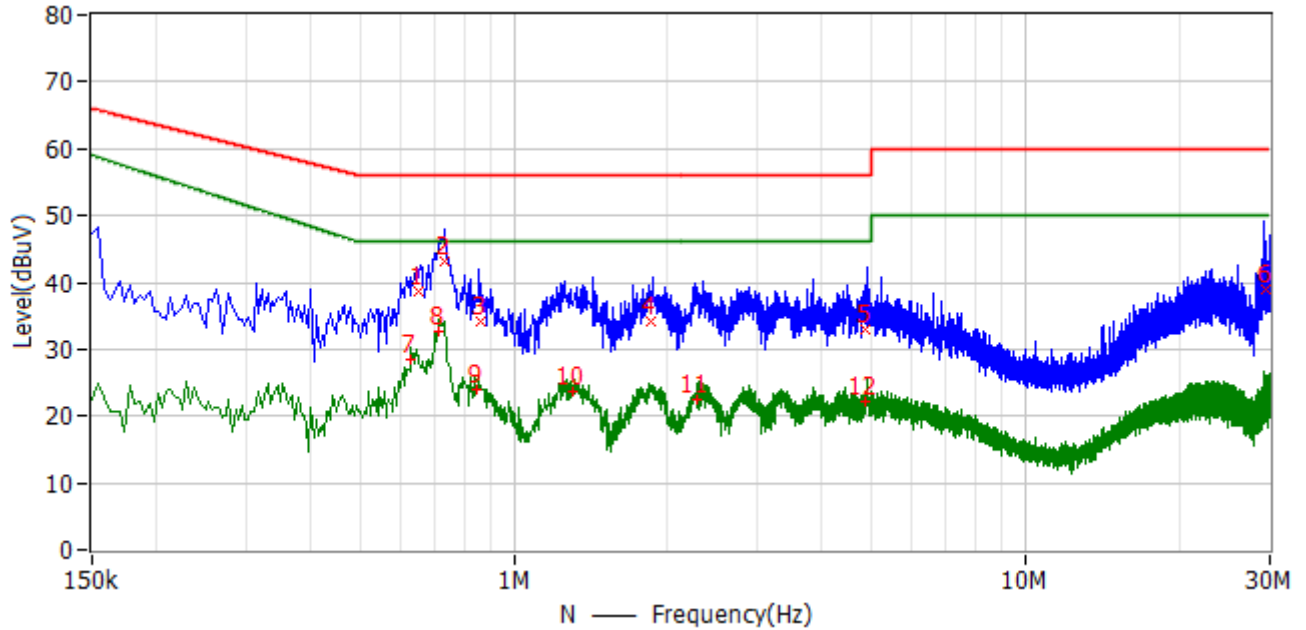

| No. | Frequency   | Limit dBuV | Level dBuV | Delta dB | Factor dB | Detector | Phase |
|-----|-------------|------------|------------|----------|-----------|----------|-------|
| 1   | 654.000 kHz | 56.0       | 38.8       | -17.2    | 10.4      | QP       | N     |
| 2   | 730.000 kHz | 56.0       | 43.0       | -13.0    | 10.3      | QP       | N     |
| 3   | 862.000 kHz | 56.0       | 34.1       | -21.9    | 10.4      | QP       | N     |
| 4   | 1.854 MHz   | 56.0       | 34.2       | -21.8    | 10.4      | QP       | N     |
| 5   | 4.870 MHz   | 56.0       | 32.9       | -23.1    | 10.5      | QP       | N     |
| 6   | 29.446 MHz  | 60.0       | 39.1       | -20.9    | 10.7      | QP       | N     |
| 7   | 630.000 kHz | 46.0       | 28.4       | -17.6    | 10.4      | CAV      | N     |
| 8   | 710.000 kHz | 46.0       | 32.8       | -13.2    | 10.3      | CAV      | N     |
| 9   | 846.000 kHz | 46.0       | 24.0       | -22.0    | 10.4      | CAV      | N     |
| 10  | 1.306 MHz   | 46.0       | 23.6       | -22.4    | 10.3      | CAV      | N     |
| 11  | 2.290 MHz   | 46.0       | 22.6       | -23.4    | 10.4      | CAV      | N     |
| 12  | 4.870 MHz   | 46.0       | 22.1       | -23.9    | 10.5      | CAV      | N     |

ZSW-ZB16  
Live Line:  
Level

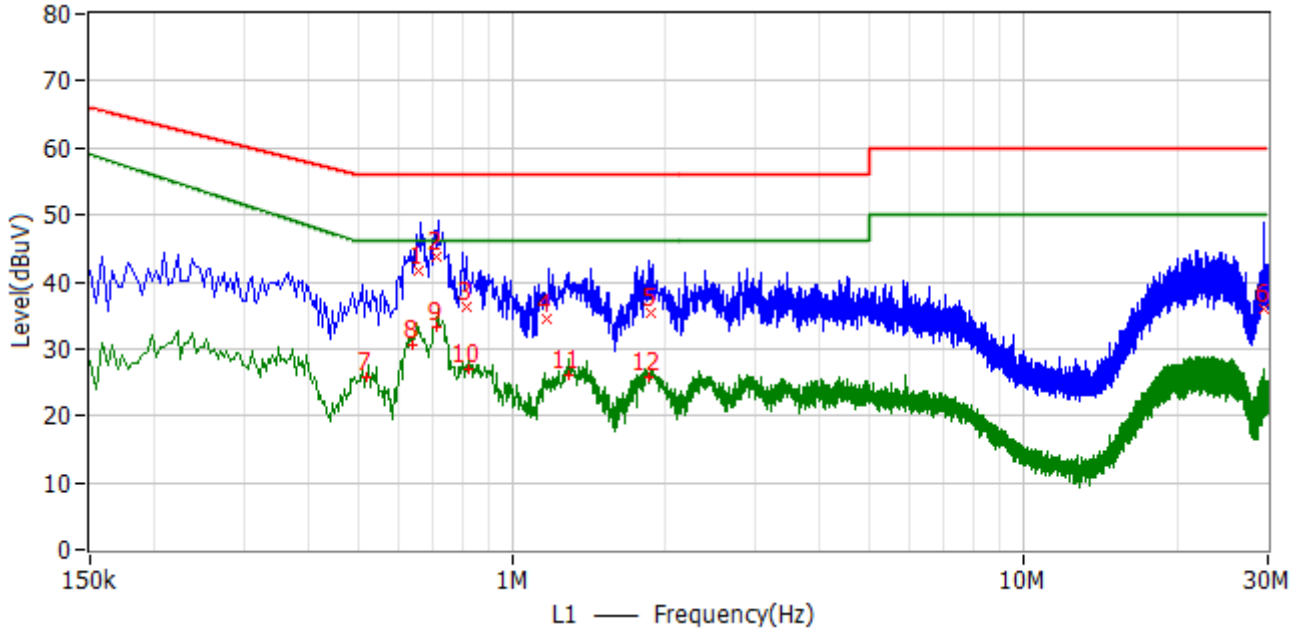

| No. | Frequency   | Limit dBuV | Level dBuV | Delta dB | Factor dB | Detector | Phase |
|-----|-------------|------------|------------|----------|-----------|----------|-------|
| 1   | 658.000 kHz | 56.0       | 41.6       | -14.4    | 10.3      | QP       | L1    |
| 2   | 714.000 kHz | 56.0       | 43.7       | -12.3    | 10.4      | QP       | L1    |
| 3   | 814.000 kHz | 56.0       | 36.3       | -19.7    | 10.3      | QP       | L1    |
| 4   | 1.170 MHz   | 56.0       | 34.4       | -21.6    | 10.4      | QP       | L1    |
| 5   | 1.870 MHz   | 56.0       | 35.5       | -20.5    | 10.5      | QP       | L1    |
| 6   | 29.374 MHz  | 60.0       | 36.0       | -24.0    | 10.8      | QP       | L1    |
| 7   | 518.000 kHz | 46.0       | 25.8       | -20.2    | 10.3      | CAV      | L1    |
| 8   | 638.000 kHz | 46.0       | 30.7       | -15.3    | 10.3      | CAV      | L1    |
| 9   | 714.000 kHz | 46.0       | 33.4       | -12.6    | 10.4      | CAV      | L1    |
| 10  | 826.000 kHz | 46.0       | 27.0       | -19.0    | 10.3      | CAV      | L1    |
| 11  | 1.298 MHz   | 46.0       | 26.2       | -19.8    | 10.3      | CAV      | L1    |
| 12  | 1.854 MHz   | 46.0       | 25.8       | -20.2    | 10.5      | CAV      | L1    |

Neutral Line:  
Level

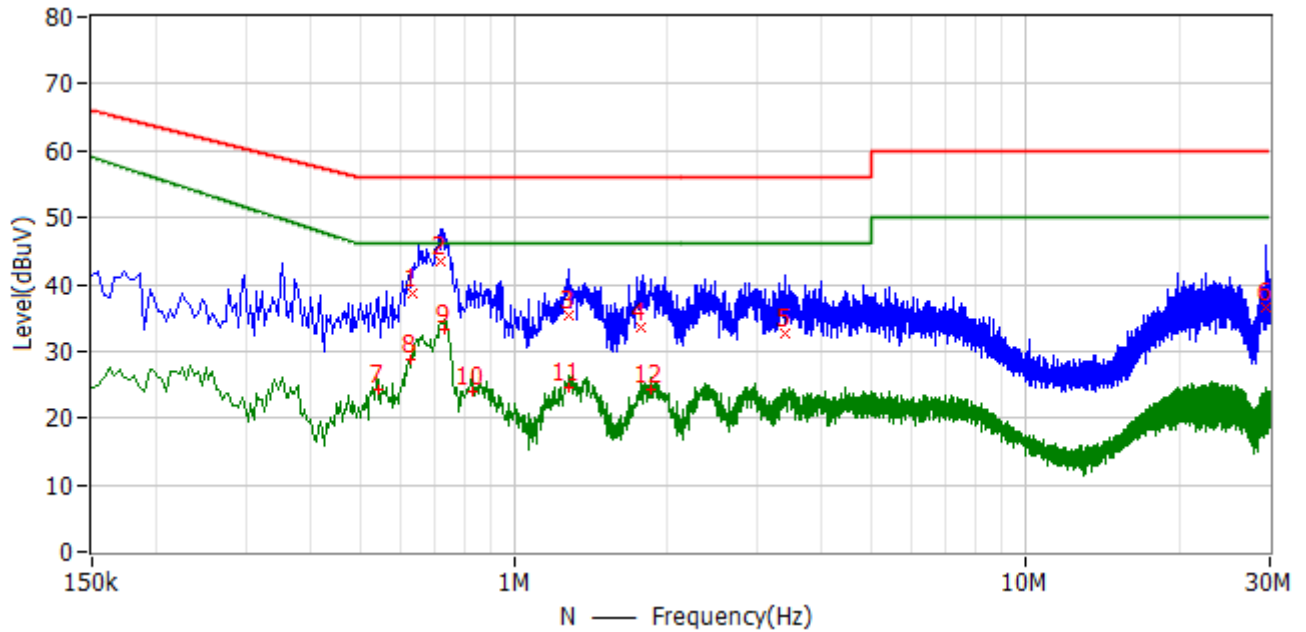

| No. | Frequency   | Limit dBuV | Level dBuV | Delta dB | Factor dB | Detector | Phase |
|-----|-------------|------------|------------|----------|-----------|----------|-------|
| 1   | 634.000 kHz | 56.0       | 38.7       | -17.3    | 10.4      | QP       | N     |
| 2   | 718.000 kHz | 56.0       | 43.4       | -12.6    | 10.3      | QP       | N     |
| 3   | 1.282 MHz   | 56.0       | 35.4       | -20.6    | 10.3      | QP       | N     |
| 4   | 1.778 MHz   | 56.0       | 33.7       | -22.3    | 10.4      | QP       | N     |
| 5   | 3.398 MHz   | 56.0       | 32.8       | -23.2    | 10.4      | QP       | N     |
| 6   | 29.386 MHz  | 60.0       | 36.7       | -23.3    | 10.7      | QP       | N     |
| 7   | 546.000 kHz | 46.0       | 24.2       | -21.8    | 10.4      | CAV      | N     |
| 8   | 630.000 kHz | 46.0       | 28.8       | -17.2    | 10.4      | CAV      | N     |
| 9   | 734.000 kHz | 46.0       | 33.4       | -12.6    | 10.3      | CAV      | N     |
| 10  | 834.000 kHz | 46.0       | 23.9       | -22.1    | 10.4      | CAV      | N     |
| 11  | 1.278 MHz   | 46.0       | 24.7       | -21.3    | 10.3      | CAV      | N     |
| 12  | 1.858 MHz   | 46.0       | 24.2       | -21.8    | 10.4      | CAV      | N     |

ZSW-ZB13 with Alternative main PCB, synchronous motor and water pump  
Live Line:  
Level

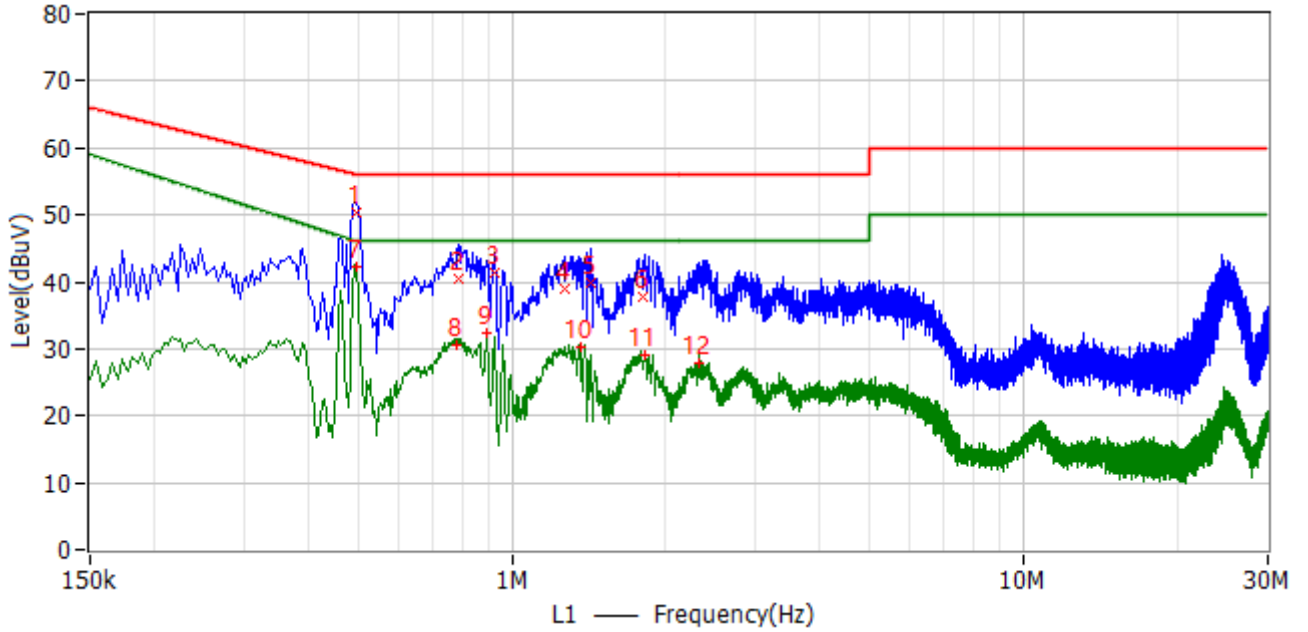

| No. | Frequency   | Limit dBuV | Level dBuV | Delta dB | Factor dB | Detector | Phase |
|-----|-------------|------------|------------|----------|-----------|----------|-------|
| 1   | 498.000 kHz | 56.0       | 50.3       | -5.8     | 10.3      | QP       | L1    |
| 2   | 790.000 kHz | 56.0       | 40.4       | -15.6    | 10.3      | QP       | L1    |
| 3   | 926.000 kHz | 56.0       | 41.2       | -14.8    | 10.3      | QP       | L1    |
| 4   | 1.274 MHz   | 56.0       | 39.1       | -16.9    | 10.3      | QP       | L1    |
| 5   | 1.430 MHz   | 56.0       | 40.0       | -16.0    | 10.3      | QP       | L1    |
| 6   | 1.806 MHz   | 56.0       | 37.9       | -18.1    | 10.5      | QP       | L1    |
| 7   | 498.000 kHz | 46.0       | 42.2       | -3.8     | 10.3      | CAV      | L1    |
| 8   | 782.000 kHz | 46.0       | 30.7       | -15.3    | 10.3      | CAV      | L1    |
| 9   | 894.000 kHz | 46.0       | 32.3       | -13.7    | 10.2      | CAV      | L1    |
| 10  | 1.362 MHz   | 46.0       | 30.4       | -15.6    | 10.3      | CAV      | L1    |
| 11  | 1.818 MHz   | 46.0       | 29.2       | -16.8    | 10.5      | CAV      | L1    |
| 12  | 2.314 MHz   | 46.0       | 27.8       | -18.2    | 10.6      | CAV      | L1    |

Test Report No.: EFSH25090011-IE-01-E01-A2

Eurofins Electrical Testing Service (Shanghai) Co., Ltd.  
Building 18, No.2168 Chenhang Highway, Minhang District, Shanghai, China

Neutral Line:  
Level

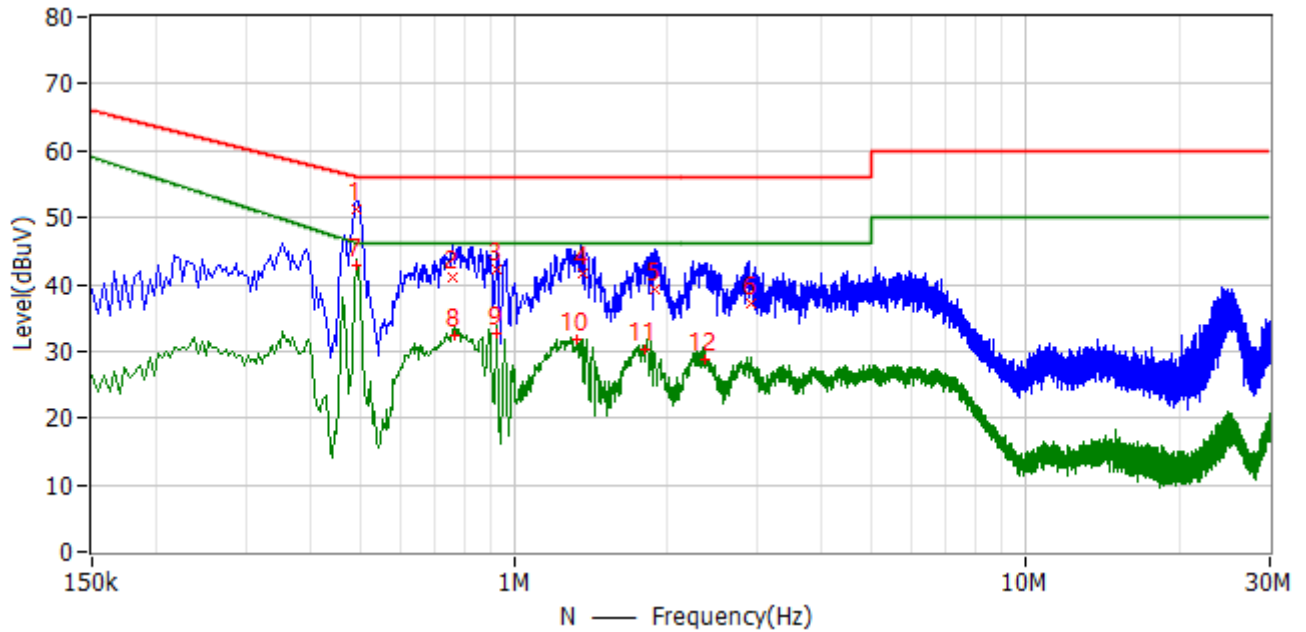

| No. | Frequency   | Limit dBuV | Level dBuV | Delta dB | Factor dB | Detector | Phase |
|-----|-------------|------------|------------|----------|-----------|----------|-------|
| 1   | 494.000 kHz | 56.1       | 51.2       | -4.9     | 10.3      | QP       | N     |
| 2   | 762.000 kHz | 56.0       | 41.0       | -15.0    | 10.3      | QP       | N     |
| 3   | 926.000 kHz | 56.0       | 42.1       | -13.9    | 10.3      | QP       | N     |
| 4   | 1.362 MHz   | 56.0       | 41.7       | -14.3    | 10.4      | QP       | N     |
| 5   | 1.882 MHz   | 56.0       | 39.3       | -16.7    | 10.4      | QP       | N     |
| 6   | 2.898 MHz   | 56.0       | 37.2       | -18.8    | 10.5      | QP       | N     |
| 7   | 494.000 kHz | 46.1       | 42.9       | -3.2     | 10.3      | CAV      | N     |
| 8   | 766.000 kHz | 46.0       | 32.4       | -13.6    | 10.3      | CAV      | N     |
| 9   | 926.000 kHz | 46.0       | 32.7       | -13.3    | 10.3      | CAV      | N     |
| 10  | 1.330 MHz   | 46.0       | 31.7       | -14.3    | 10.4      | CAV      | N     |
| 11  | 1.798 MHz   | 46.0       | 30.2       | -15.8    | 10.4      | CAV      | N     |
| 12  | 2.362 MHz   | 46.0       | 28.9       | -17.1    | 10.5      | CAV      | N     |

## 4.2 Disturbance power

This clause lays down the general requirements for the measurement of disturbance power produced at the terminals of apparatus.

### 4.2.1 Limits

| Frequency range<br>MHz                              | Limit<br>dB (pW) |          |
|---|------------------|----------|
|   | Quasi-peak       | Average  |
| 30 to 300   | 45 to 55         | 35 to 45 |
| Note1: Increasing linearly with the frequency from. |                  |          |

### 4.2.2 Measurement procedure

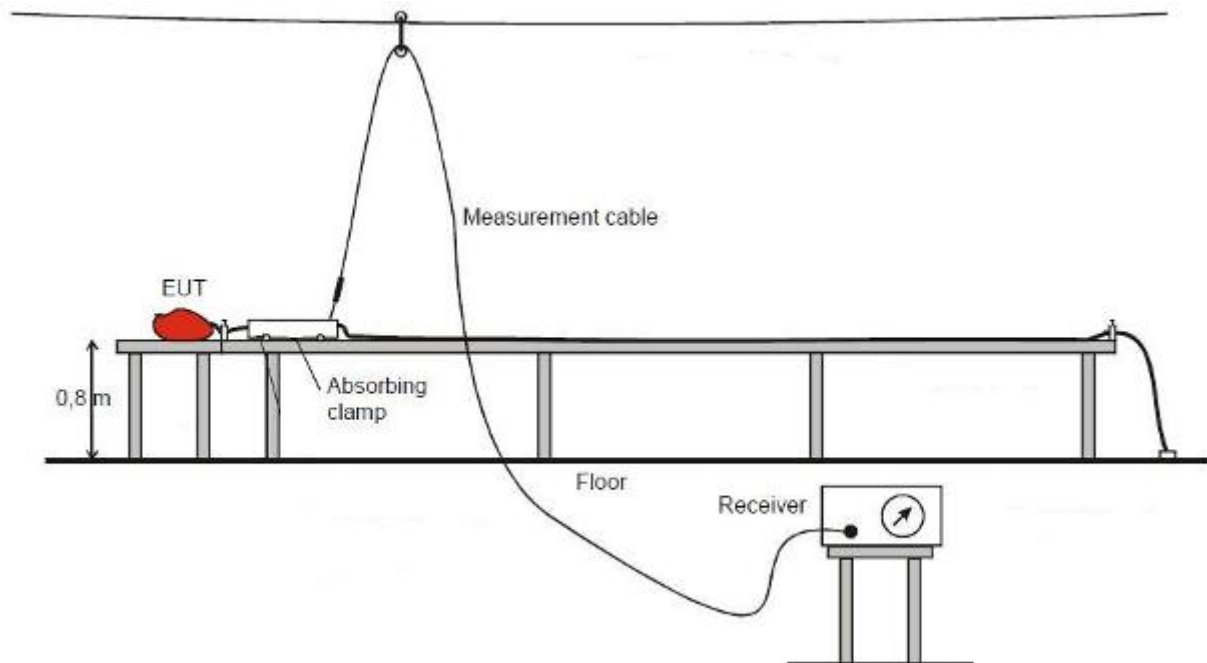

The test configuration corresponds to the standard EN IEC 55014-1. The equipment under test is placed on a non metallic table with 0,8 m high. The lead to be measured is stretched horizontally in a straight line, to permit variation in position of the absorbing clamp along the lead to find the maximum indication. The lead shall be at least length of 6 meter. Before get the final emission results with quasi-peak(QP) detector and average(AVG) detector, a pre-scan was performed with the peak(PK) detector to find out the maximum emission data plots of the EUT. The absorbing clamp is placed around the lead.

### 4.2.3 Measurement uncertainty

$U_{lab}(cond) = 4.08 \text{ dB}$  at confidence of 95%,  $k=2$

#### 4.2.4 Results

ZSW-ZB13  
Level

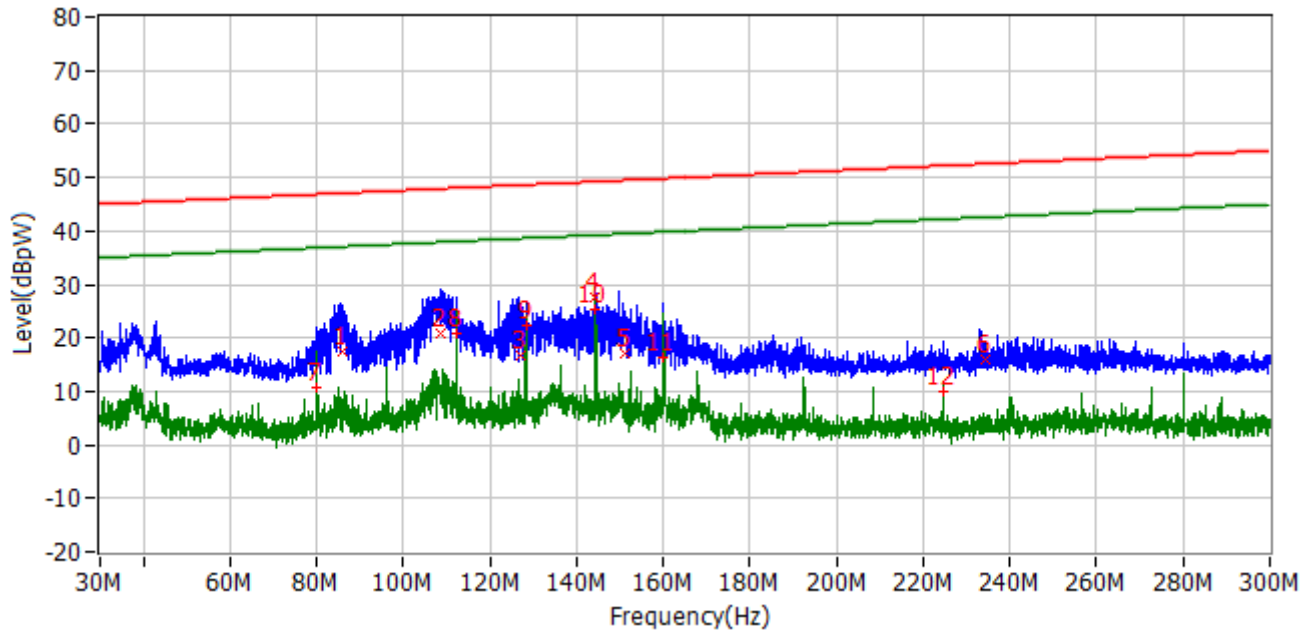

| No. | Frequency   | Limit dBpW | Level dBpW | Delta dB | Factor dB | Detector |
|-----|-------------|------------|------------|----------|-----------|----------|
| 1   | 85.860 MHz  | 47.1       | 17.6       | -29.5    | 7.6       | QP       |
| 2   | 108.720 MHz | 47.9       | 20.7       | -27.3    | 7.5       | QP       |
| 3   | 126.900 MHz | 48.6       | 16.6       | -32.0    | 7.7       | QP       |
| 4   | 144.360 MHz | 49.2       | 27.6       | -21.7    | 7.7       | QP       |
| 5   | 151.020 MHz | 49.5       | 16.9       | -32.6    | 7.7       | QP       |
| 6   | 234.240 MHz | 52.6       | 15.9       | -36.6    | 8.2       | QP       |
| 7   | 79.980 MHz  | 36.9       | 10.7       | -26.2    | 7.6       | CAV      |
| 8   | 112.320 MHz | 38.0       | 20.8       | -17.3    | 7.5       | CAV      |
| 9   | 128.340 MHz | 38.6       | 22.2       | -16.4    | 7.7       | CAV      |
| 10  | 144.360 MHz | 39.2       | 25.5       | -13.8    | 7.7       | CAV      |
| 11  | 160.020 MHz | 39.8       | 16.3       | -23.5    | 7.7       | CAV      |
| 12  | 224.580 MHz | 42.2       | 9.9        | -32.3    | 8.1       | CAV      |

ZSW-ZB14  
Level

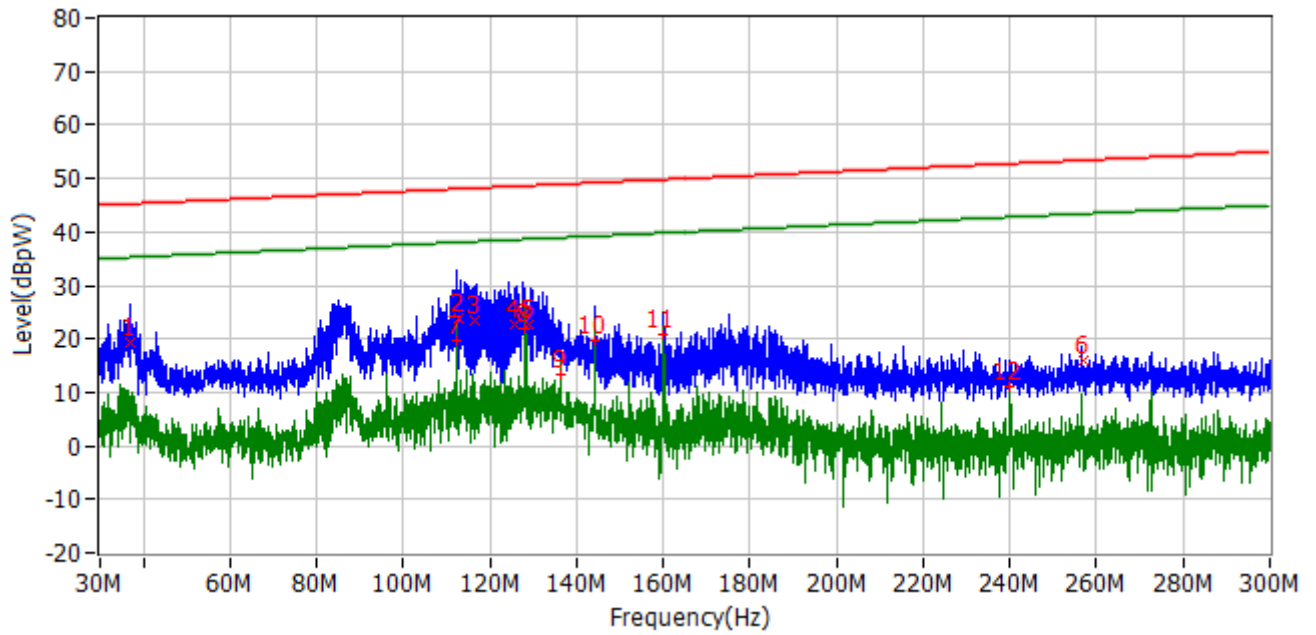

| No. | Frequency   | Limit dBpW | Level dBpW | Delta dB | Factor dB | Detector |
|-----|-------------|------------|------------|----------|-----------|----------|
| 1   | 36.840 MHz  | 45.3       | 19.5       | -25.7    | 7.0       | QP       |
| 2   | 112.920 MHz | 48.1       | 23.8       | -24.3    | 7.6       | QP       |
| 3   | 116.520 MHz | 48.2       | 23.5       | -24.7    | 7.6       | QP       |
| 4   | 125.520 MHz | 48.5       | 22.6       | -25.9    | 7.7       | QP       |
| 5   | 129.120 MHz | 48.7       | 22.6       | -26.1    | 7.7       | QP       |
| 6   | 257.040 MHz | 53.4       | 15.8       | -37.6    | 8.5       | QP       |
| 7   | 112.200 MHz | 38.0       | 19.6       | -18.5    | 7.5       | CAV      |
| 8   | 128.160 MHz | 38.6       | 22.0       | -16.6    | 7.7       | CAV      |
| 9   | 136.260 MHz | 38.9       | 13.3       | -25.6    | 7.7       | CAV      |
| 10  | 144.240 MHz | 39.2       | 19.6       | -19.6    | 7.7       | CAV      |
| 11  | 160.020 MHz | 39.8       | 20.8       | -19.0    | 7.7       | CAV      |
| 12  | 240.000 MHz | 42.8       | 11.0       | -31.8    | 8.3       | CAV      |

ZSW-ZB15  
Level

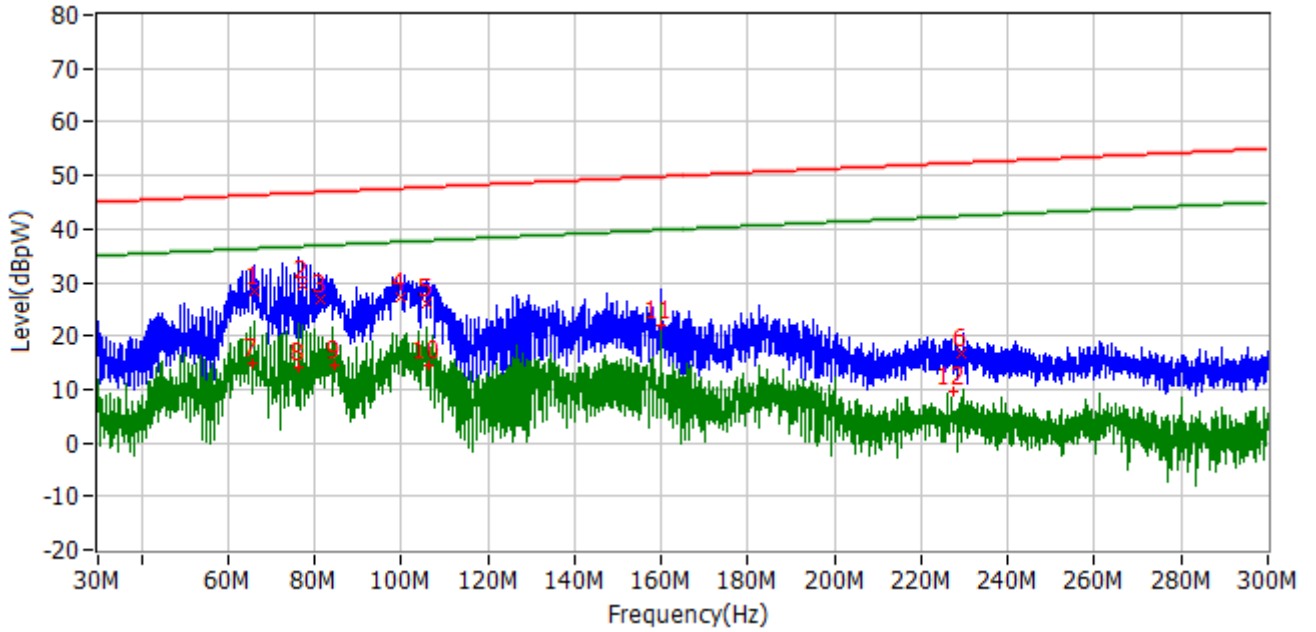

| No. | Frequency   | Limit dBpW | Level dBpW | Delta dB | Factor dB | Detector |
|-----|-------------|------------|------------|----------|-----------|----------|
| 1   | 66.240 MHz  | 46.3       | 28.2       | -18.1    | 7.6       | QP       |
| 2   | 76.980 MHz  | 46.7       | 29.6       | -17.1    | 7.6       | QP       |
| 3   | 81.420 MHz  | 46.9       | 26.8       | -20.1    | 7.6       | QP       |
| 4   | 99.600 MHz  | 47.6       | 27.2       | -20.4    | 7.5       | QP       |
| 5   | 105.840 MHz | 47.8       | 26.0       | -21.8    | 7.5       | QP       |
| 6   | 229.080 MHz | 52.4       | 16.7       | -35.7    | 8.1       | QP       |
| 7   | 65.760 MHz  | 36.3       | 14.8       | -21.5    | 7.6       | CAV      |
| 8   | 76.200 MHz  | 36.7       | 14.1       | -22.6    | 7.6       | CAV      |
| 9   | 84.540 MHz  | 37.0       | 14.3       | -22.7    | 7.6       | CAV      |
| 10  | 106.320 MHz | 37.8       | 14.3       | -23.5    | 7.5       | CAV      |
| 11  | 160.020 MHz | 39.8       | 21.8       | -18.0    | 7.7       | CAV      |
| 12  | 227.340 MHz | 42.3       | 9.5        | -32.8    | 8.1       | CAV      |

ZSW-ZB16  
Level

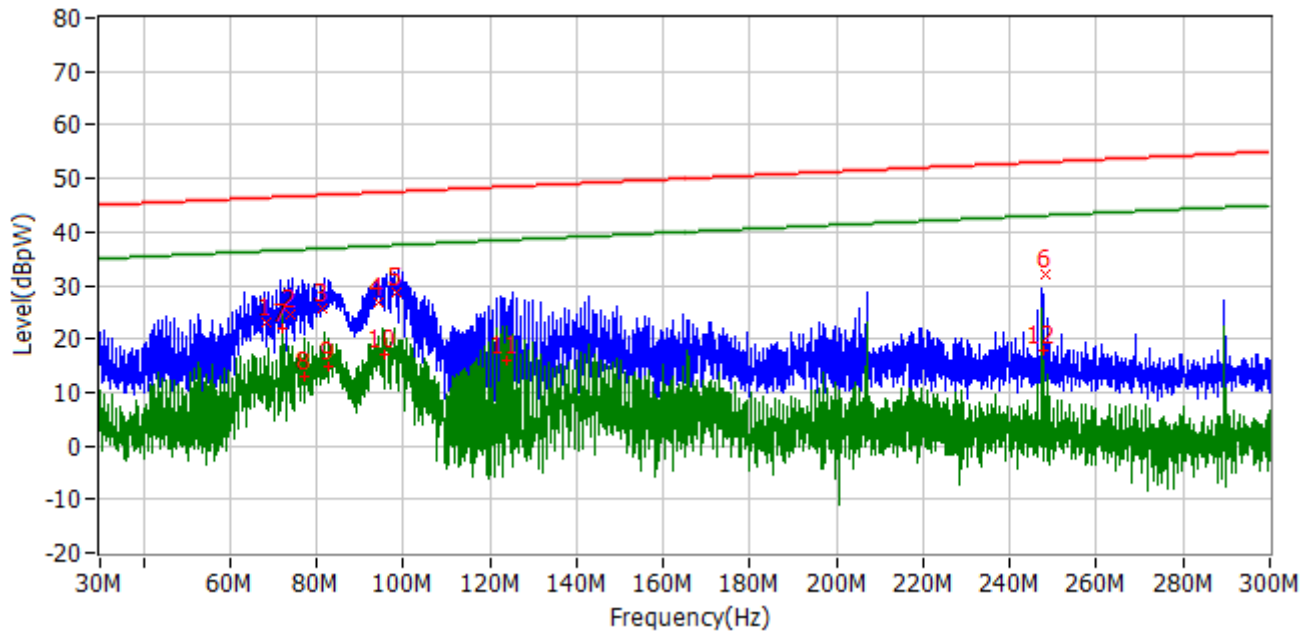

| No. | Frequency   | Limit dBpW | Level dBpW | Delta dB | Factor dB | Detector |
|-----|-------------|------------|------------|----------|-----------|----------|
| 1   | 68.220 MHz  | 46.4       | 23.2       | -23.3    | 7.6       | QP       |
| 2   | 73.740 MHz  | 46.6       | 24.7       | -21.9    | 7.6       | QP       |
| 3   | 81.540 MHz  | 46.9       | 25.6       | -21.4    | 7.6       | QP       |
| 4   | 94.260 MHz  | 47.4       | 27.0       | -20.3    | 7.6       | QP       |
| 5   | 98.640 MHz  | 47.5       | 28.7       | -18.8    | 7.5       | QP       |
| 6   | 248.340 MHz | 53.1       | 32.2       | -20.9    | 8.4       | QP       |
| 7   | 72.000 MHz  | 36.6       | 21.8       | -14.8    | 7.6       | CAV      |
| 8   | 76.980 MHz  | 36.7       | 13.1       | -23.6    | 7.6       | CAV      |
| 9   | 82.740 MHz  | 37.0       | 14.9       | -22.0    | 7.6       | CAV      |
| 10  | 95.700 MHz  | 37.4       | 16.9       | -20.5    | 7.6       | CAV      |
| 11  | 123.840 MHz | 38.5       | 15.8       | -22.7    | 7.7       | CAV      |
| 12  | 247.620 MHz | 43.1       | 17.8       | -25.3    | 8.4       | CAV      |

ZSW-ZB13 with Alternative main PCB, synchronous motor and water pump  
Level

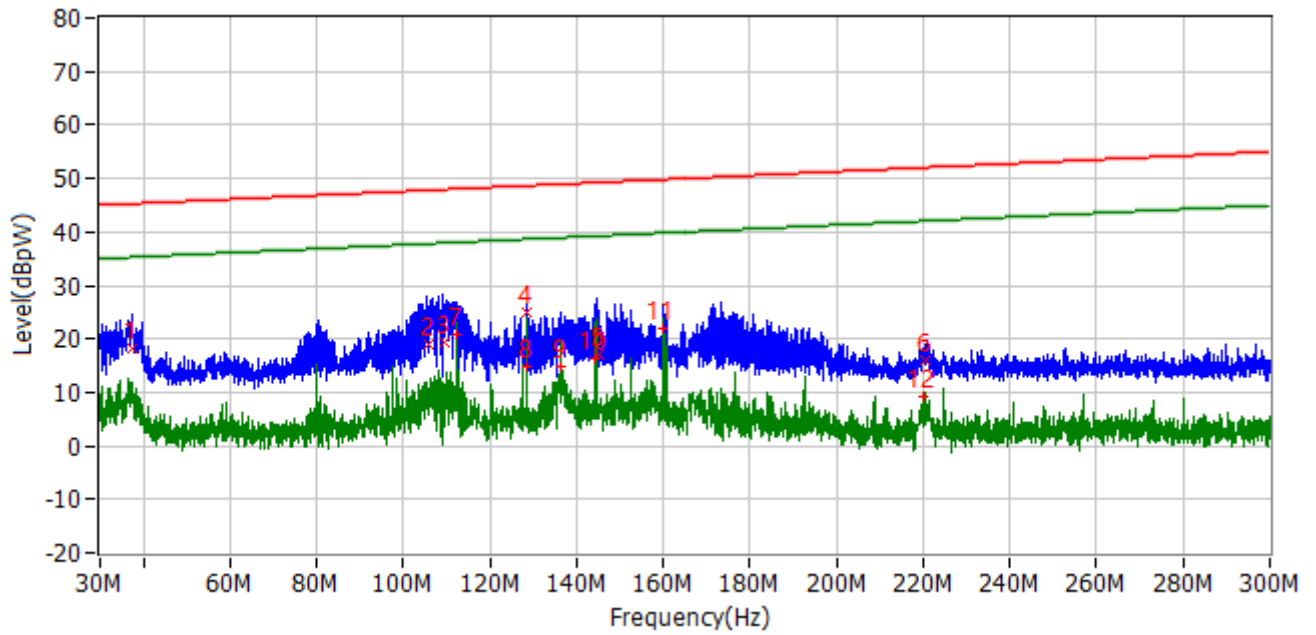

| No. | Frequency   | Limit dBpW | Level dBpW | Delta dB | Factor dB | Detector |
|-----|-------------|------------|------------|----------|-----------|----------|
| 1   | 37.560 MHz  | 45.3       | 18.2       | -27.1    | 7.0       | QP       |
| 2   | 105.960 MHz | 47.8       | 19.1       | -28.8    | 7.5       | QP       |
| 3   | 109.680 MHz | 48.0       | 19.4       | -28.5    | 7.5       | QP       |
| 4   | 128.400 MHz | 48.6       | 24.9       | -23.8    | 7.7       | QP       |
| 5   | 145.080 MHz | 49.3       | 17.0       | -32.3    | 7.7       | QP       |
| 6   | 220.380 MHz | 52.1       | 16.1       | -35.9    | 8.1       | QP       |
| 7   | 112.380 MHz | 38.1       | 20.9       | -17.2    | 7.5       | CAV      |
| 8   | 128.520 MHz | 38.6       | 14.8       | -23.8    | 7.7       | CAV      |
| 9   | 136.500 MHz | 38.9       | 15.0       | -24.0    | 7.7       | CAV      |
| 10  | 144.420 MHz | 39.2       | 16.4       | -22.9    | 7.7       | CAV      |
| 11  | 160.020 MHz | 39.8       | 21.8       | -18.0    | 7.7       | CAV      |
| 12  | 220.080 MHz | 42.0       | 9.1        | -33.0    | 8.1       | CAV      |

### 4.3 Harmonic Current Emissions

This part deals with the limitation of harmonic currents injected into the public supply system.

#### 4.3.1 Limits

**Table 1 – Limits for Class A equipment**

| Harmonic order<br>$h$ | Maximum permissible<br>harmonic current<br>A |
|-----------------------|--|
| <b>Odd harmonics</b>  |  |
| 3                     | 2,30   |
| 5                     | 1,14   |
| 7                     | 0,77   |
| 9                     | 0,40   |
| 11                    | 0,33   |
| 13                    | 0,21   |
| $15 \leq h \leq 39$   | $0,15 \frac{15}{h}$                          |
| <b>Even harmonics</b> |  |
| 2                     | 1,08   |
| 4                     | 0,43   |
| 6                     | 0,30   |
| $8 \leq h \leq 40$    | $0,23 \frac{8}{h}$                           |

**Table 2 – Limits for Class C equipment <sup>a</sup>**

| Harmonic order<br>$h$  | Maximum permissible harmonic<br>current expressed as a percentage of<br>the input current at the fundamental<br>frequency<br>% |
|--|--|
| 2  | 2  |
| 3  | 27 <sup>b</sup>  |
| 5  | 10   |
| 7  | 7  |
| 9  | 5  |
| $11 \leq h \leq 39$<br>(odd harmonics only)  | 3  |
| <sup>a</sup> For some Class C products, other emission limits apply (see 7.4).<br><sup>b</sup> The limit is determined based on the assumption of modern lighting technologies having power factors of 0,90 or higher. |  |

**Table 3 – Limits for Class D equipment**

| Harmonic order<br><i>h</i>                  | Maximum permissible<br>harmonic current per<br>watt<br>mA/W | Maximum permissible<br>harmonic current<br>A |
|---|---|--|
| 3   | 3,4   | 2,30   |
| 5   | 1,9   | 1,14   |
| 7   | 1,0   | 0,77   |
| 9   | 0,5   | 0,40   |
| 11  | 0,35  | 0,33   |
| $13 \leq h \leq 39$<br>(odd harmonics only) | $\frac{3,85}{h}$  | See Table 1                                  |

**Limits for Class A equipment:**

For Class A equipment, the harmonics of the input current shall not exceed the values given In Table 1

**Limits for Class B equipment:**

For Class B equipment, the harmonics of the input current shall not exceed the values given in Table 1 multiplied by a factor of 1,5.

**Limits for Class C equipment:**

Rated power > 25 W:

For luminaires with incandescent lamps and built-in phase control dimming having a rated power greater than 25W, the harmonics of the input current shall not exceed the limits givein in Table 1.

For any other lighting equipment having a rated power greater than 25W, the harmonics of the input current shall not exceed the relative limits given in Table 2.

Rated power  $\geq 5$  W and  $\leq 25$  W:

Lighting equipment having a rated power greater than or equal to 5 W and less than or equal to 25 W shall comply with one of the following three sets of requirement:

- The harmonic currents shall not exceed the power-related limits of Table 3, column 2.

Or

- The third harmonic current, expressed as a percentage of the fundamental current, shall not exceed 86 % and the fifth harmonic current shall not exceed 61 %. In addition, the waveform of the input current shall be such that it reaches the 5 % current threshold before or at 60°, has its peak value before or at 65° and does not fall below the 5 % current threshold before 90°, referenced to any zero crossing of the fundamental supply voltage. The current threshold is 5 % of the highest absolute peak value that occurs in the measurement window, and the phase angle measurements are made on the cycle that includes this absolute peak value.

Or

- The THD shall not exceed 70%. The third order harmonic current, expressed as a percentage of the fundamental current, shall not exceed 35%, the fifth order current shall not exceed 25%, the seventh order current shall not exceed 30%, the ninth and eleventh order currents shall not exceed 20% and the second order current shall not exceed 5%.

**Limits for Class D equipment:**

For Class D equipment, the input current at harmonic frequencies shall not exceed the values given in Table 3.

**For the following categories of equipment, limits are not specified:**

Lighting equipment with a rated power less than but not equal to 5W;  
 Equipment with rated power of 75 W or less, other than lighting equipment;  
 Professional equipment with a total rated power greater than 1 kW;  
 Independent phase control dimmers with a rated power less than or equal to 1 kW when operating incandescent lamps, or with a rated power less than or equal to 200 W for trailing edge dimmers when operating lighting equipment other than incandescent lamps, or with a rated power less than or equal to 100 W for leading edge dimmers when operating lighting equipment other than incandescent lamps.

**4.3.2 Measurement procedure**

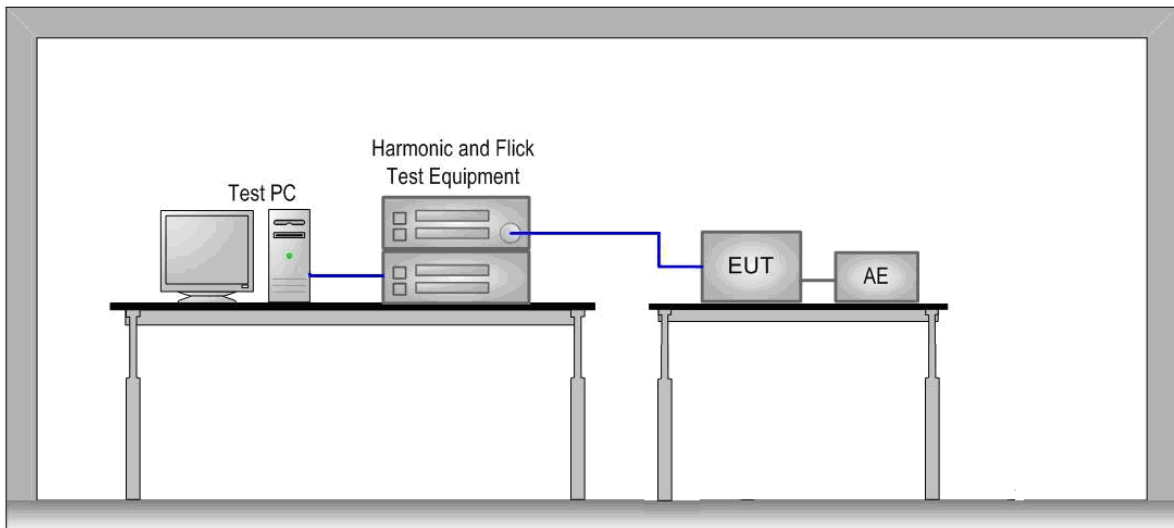

The equipment under test is placed on a wooden table with a height of 0,8 m in the EMC lab. For each harmonic order, measure the 1,5 s smoothed RMS harmonic current in each DFT time window and calculate the arithmetic average of the measured values from the DFT time windows, over the entire observation period.

The average values for the individual harmonic currents, taken over the entire test observation period shall be less than or equal to the applicable limits.

For each harmonic order, all 1.5 s smoothed RMS harmonic current values shall be either:

- a) Less than or equal to 150% of the applicable limits, or
- b) Less than or equal to 200% of the applicable limits under the following conditions:
  - 1) The EUT belongs to Class A for harmonics,
  - 2) The excursion beyond 150% of the applicable limits lasts less than 10% of the test observation period or in total 10 min, whichever is smaller, and
  - 3) The average value of the harmonic current, taken over the entire test observation period, is less than 90% of the applicable limits.

4.3.3 Results

**ZSW-ZB13  
Harmonics – Class-A**

Test Result: Pass Source qualification: Normal

Current & voltage waveforms

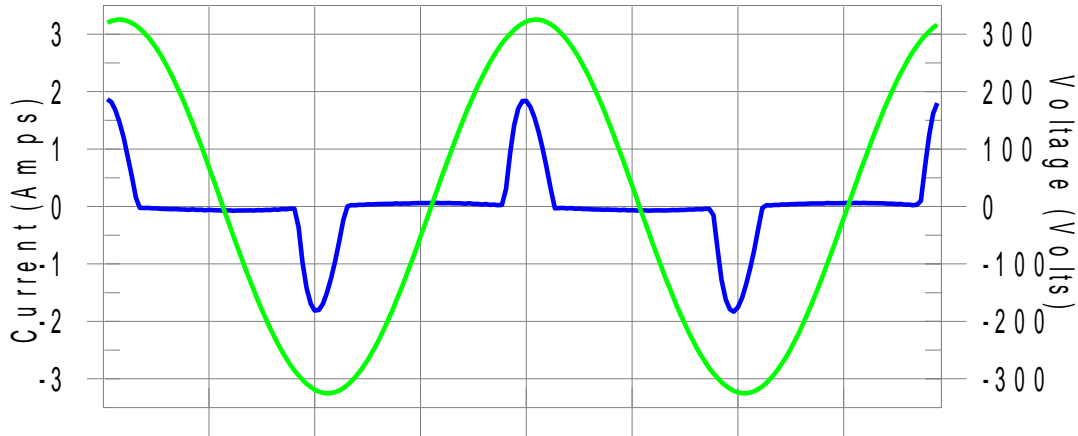

Harmonics and Class A limit line

European Limits

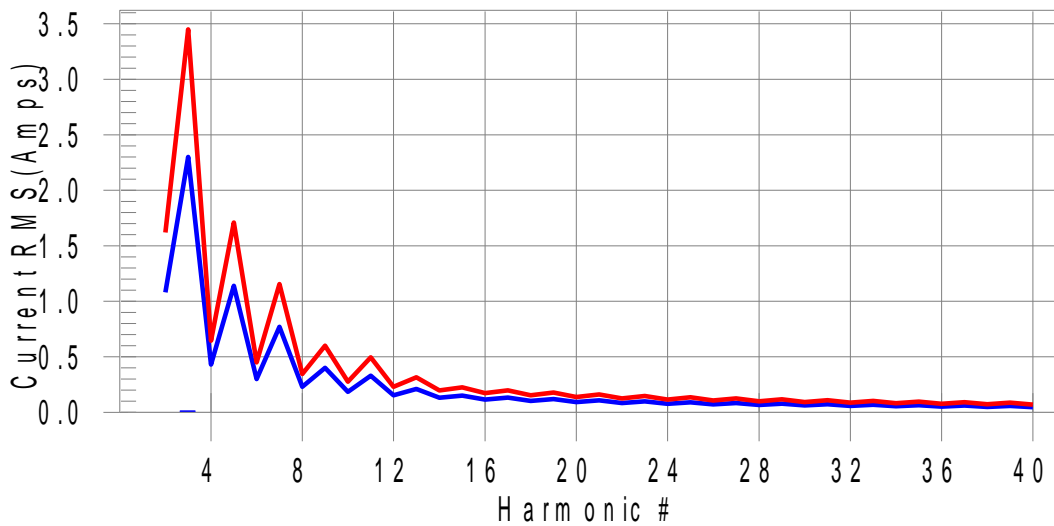

**Test result: Pass Worst harmonic was #7 with 16.4% of the limit.**

### Current Test Result Summary

Test Result: Pass      Source qualification: Normal  
 THC(A): 0.016      I-THD(%): 32.0      POHC(A): 0.000      POHC Limit(A): 0.251  
 Highest parameter values during test:

|                |        |                |       |
|----------------|--------|----------------|-------|
| V_RMS (Volts): | 230.17 | Frequency(Hz): | 50.00 |
| I_Peak (Amps): | 1.871  | I_RMS (Amps):  | 0.643 |
| I_Fund (Amps): | 0.404  | Crest Factor:  | 8.840 |
| Power (Watts): | 90.4   | Power Factor:  | 0.612 |

| Harm# | Harms(avg) | 100%Limit | %of Limit | Harms(max) | 150%Limit | %of Limit | Status |
|-------|------------|-----------|-----------|------------|-----------|-----------|--------|
| 2     | 0.001      | 1.080     | N/A       | 0.007      | 1.620     | N/A       | Pass   |
| 3     | 0.011      | 2.300     | 0.5       | 0.352      | 3.450     | 10.2      | Pass   |
| 4     | 0.001      | 0.430     | N/A       | 0.006      | 0.645     | N/A       | Pass   |
| 5     | 0.008      | 1.140     | 0.7       | 0.279      | 1.710     | 16.3      | Pass   |
| 6     | 0.001      | 0.300     | N/A       | 0.004      | 0.450     | N/A       | Pass   |
| 7     | 0.006      | 0.770     | 0.7       | 0.189      | 1.155     | 16.4      | Pass   |
| 8     | 0.001      | 0.230     | N/A       | 0.003      | 0.345     | N/A       | Pass   |
| 9     | 0.003      | 0.400     | N/A       | 0.103      | 0.600     | N/A       | Pass   |
| 10    | 0.001      | 0.184     | N/A       | 0.002      | 0.276     | N/A       | Pass   |
| 11    | 0.002      | 0.330     | N/A       | 0.039      | 0.495     | N/A       | Pass   |
| 12    | 0.001      | 0.153     | N/A       | 0.002      | 0.230     | N/A       | Pass   |
| 13    | 0.001      | 0.210     | N/A       | 0.027      | 0.315     | N/A       | Pass   |
| 14    | 0.001      | 0.131     | N/A       | 0.002      | 0.197     | N/A       | Pass   |
| 15    | 0.002      | 0.150     | N/A       | 0.036      | 0.225     | N/A       | Pass   |
| 16    | 0.001      | 0.115     | N/A       | 0.002      | 0.173     | N/A       | Pass   |
| 17    | 0.001      | 0.132     | N/A       | 0.030      | 0.198     | N/A       | Pass   |
| 18    | 0.001      | 0.102     | N/A       | 0.001      | 0.153     | N/A       | Pass   |
| 19    | 0.001      | 0.118     | N/A       | 0.016      | 0.178     | N/A       | Pass   |
| 20    | 0.001      | 0.092     | N/A       | 0.001      | 0.138     | N/A       | Pass   |
| 21    | 0.001      | 0.107     | N/A       | 0.007      | 0.161     | N/A       | Pass   |
| 22    | 0.001      | 0.084     | N/A       | 0.001      | 0.125     | N/A       | Pass   |
| 23    | 0.001      | 0.098     | N/A       | 0.013      | 0.147     | N/A       | Pass   |
| 24    | 0.001      | 0.077     | N/A       | 0.001      | 0.115     | N/A       | Pass   |
| 25    | 0.001      | 0.090     | N/A       | 0.013      | 0.135     | N/A       | Pass   |
| 26    | 0.000      | 0.071     | N/A       | 0.001      | 0.107     | N/A       | Pass   |
| 27    | 0.001      | 0.083     | N/A       | 0.009      | 0.125     | N/A       | Pass   |
| 28    | 0.000      | 0.066     | N/A       | 0.001      | 0.099     | N/A       | Pass   |
| 29    | 0.001      | 0.078     | N/A       | 0.003      | 0.116     | N/A       | Pass   |
| 30    | 0.000      | 0.061     | N/A       | 0.001      | 0.092     | N/A       | Pass   |
| 31    | 0.001      | 0.073     | N/A       | 0.006      | 0.109     | N/A       | Pass   |
| 32    | 0.000      | 0.058     | N/A       | 0.001      | 0.086     | N/A       | Pass   |
| 33    | 0.001      | 0.068     | N/A       | 0.007      | 0.102     | N/A       | Pass   |
| 34    | 0.000      | 0.054     | N/A       | 0.001      | 0.081     | N/A       | Pass   |
| 35    | 0.001      | 0.064     | N/A       | 0.005      | 0.096     | N/A       | Pass   |
| 36    | 0.000      | 0.051     | N/A       | 0.001      | 0.077     | N/A       | Pass   |
| 37    | 0.000      | 0.061     | N/A       | 0.002      | 0.091     | N/A       | Pass   |
| 38    | 0.000      | 0.048     | N/A       | 0.001      | 0.073     | N/A       | Pass   |
| 39    | 0.000      | 0.058     | N/A       | 0.003      | 0.087     | N/A       | Pass   |
| 40    | 0.000      | 0.046     | N/A       | 0.000      | 0.069     | N/A       | Pass   |

**ZSW-ZB14  
Harmonics – Class-A**

Test Result: Pass      Source qualification: Normal

**Current & voltage waveforms**

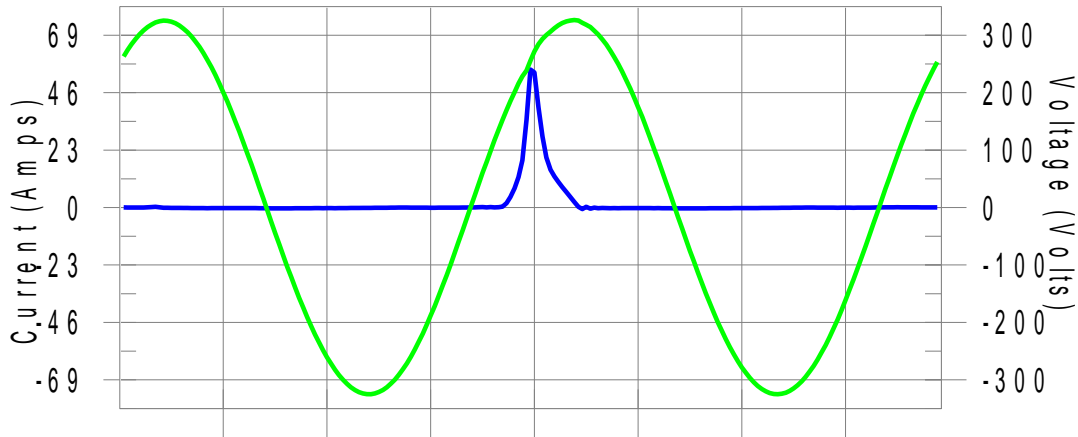

**Harmonics and Class A limit line      European Limits**

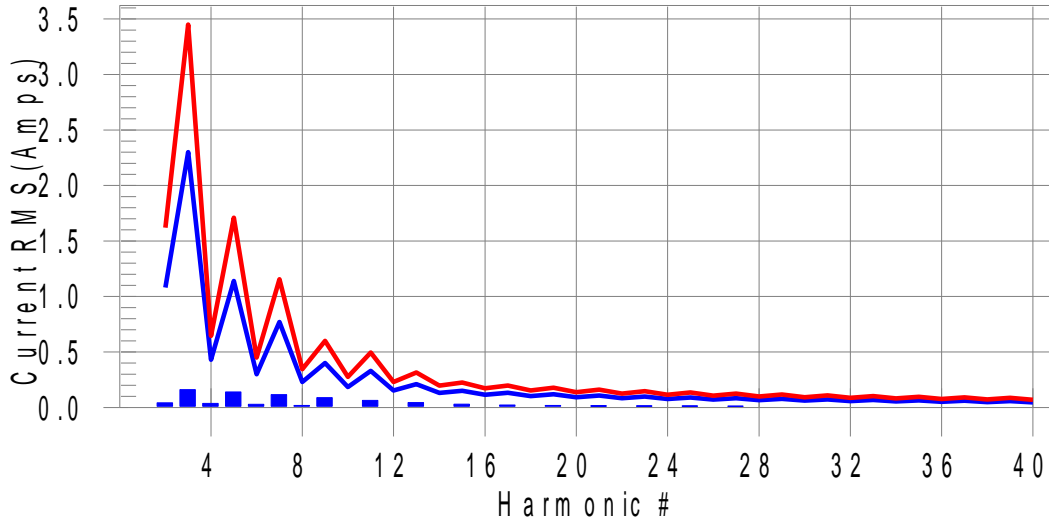

**Test result: Pass      Worst harmonic was #6 with 52.2% of the limit.**

### Current Test Result Summary

Test Result: Pass      Source qualification: Normal  
 THC(A): 0.284      I-THD(%): 105.0      POHC(A): 0.037      POHC Limit(A): 0.251  
 Highest parameter values during test:

|                |        |                |        |
|----------------|--------|----------------|--------|
| V_RMS (Volts): | 230.19 | Frequency(Hz): | 50.00  |
| I_Peak (Amps): | 57.742 | I_RMS (Amps):  | 3.314  |
| I_Fund (Amps): | 0.557  | Crest Factor:  | 17.425 |
| Power (Watts): | 89.4   | Power Factor:  | 0.519  |

| Harm# | Harms(avg) | 100%Limit | %of Limit | Harms(max) | 150%Limit | %of Limit | Status |
|-------|------------|-----------|-----------|------------|-----------|-----------|--------|
| 2     | 0.042      | 1.080     | 3.9       | 0.450      | 1.620     | 27.8      | Pass   |
| 3     | 0.161      | 2.300     | 7.0       | 0.409      | 3.450     | 11.9      | Pass   |
| 4     | 0.037      | 0.430     | 8.5       | 0.334      | 0.645     | 51.9      | Pass   |
| 5     | 0.140      | 1.140     | 12.3      | 0.333      | 1.710     | 19.5      | Pass   |
| 6     | 0.028      | 0.300     | 9.4       | 0.235      | 0.450     | 52.2      | Pass   |
| 7     | 0.115      | 0.770     | 15.0      | 0.271      | 1.155     | 23.5      | Pass   |
| 8     | 0.019      | 0.230     | 8.1       | 0.163      | 0.345     | 47.3      | Pass   |
| 9     | 0.089      | 0.400     | 22.1      | 0.204      | 0.600     | 34.0      | Pass   |
| 10    | 0.010      | 0.184     | 5.6       | 0.133      | 0.276     | 48.4      | Pass   |
| 11    | 0.064      | 0.330     | 19.4      | 0.142      | 0.495     | 28.6      | Pass   |
| 12    | 0.007      | 0.153     | 4.9       | 0.115      | 0.230     | 50.3      | Pass   |
| 13    | 0.044      | 0.210     | 20.9      | 0.106      | 0.315     | 33.7      | Pass   |
| 14    | 0.010      | 0.131     | 7.4       | 0.094      | 0.197     | 47.6      | Pass   |
| 15    | 0.030      | 0.150     | 20.0      | 0.083      | 0.225     | 37.1      | Pass   |
| 16    | 0.010      | 0.115     | 8.5       | 0.071      | 0.173     | 41.0      | Pass   |
| 17    | 0.022      | 0.132     | 16.9      | 0.058      | 0.198     | 29.5      | Pass   |
| 18    | 0.008      | 0.102     | 8.0       | 0.051      | 0.153     | 33.0      | Pass   |
| 19    | 0.019      | 0.118     | 15.7      | 0.043      | 0.178     | 24.3      | Pass   |
| 20    | 0.006      | 0.092     | 6.0       | 0.039      | 0.138     | 28.1      | Pass   |
| 21    | 0.017      | 0.107     | 15.4      | 0.037      | 0.161     | 23.3      | Pass   |
| 22    | 0.006      | 0.084     | 6.7       | 0.034      | 0.125     | 27.3      | Pass   |
| 23    | 0.015      | 0.098     | 15.5      | 0.032      | 0.147     | 21.6      | Pass   |
| 24    | 0.006      | 0.077     | 8.3       | 0.029      | 0.115     | 25.4      | Pass   |
| 25    | 0.014      | 0.090     | 15.3      | 0.027      | 0.135     | 19.9      | Pass   |
| 26    | 0.006      | 0.071     | 8.7       | 0.024      | 0.107     | 22.1      | Pass   |
| 27    | 0.012      | 0.083     | 14.5      | 0.023      | 0.125     | 18.4      | Pass   |
| 28    | 0.005      | 0.066     | 7.8       | 0.019      | 0.099     | 19.3      | Pass   |
| 29    | 0.010      | 0.078     | 13.3      | 0.020      | 0.116     | 17.0      | Pass   |
| 30    | 0.004      | 0.061     | N/A       | 0.015      | 0.092     | N/A       | Pass   |
| 31    | 0.009      | 0.073     | 12.8      | 0.019      | 0.109     | 17.5      | Pass   |
| 32    | 0.004      | 0.058     | N/A       | 0.011      | 0.086     | N/A       | Pass   |
| 33    | 0.009      | 0.068     | 13.9      | 0.020      | 0.102     | 19.8      | Pass   |
| 34    | 0.005      | 0.054     | N/A       | 0.010      | 0.081     | N/A       | Pass   |
| 35    | 0.010      | 0.064     | 15.1      | 0.021      | 0.096     | 22.2      | Pass   |
| 36    | 0.005      | 0.051     | N/A       | 0.010      | 0.077     | N/A       | Pass   |
| 37    | 0.009      | 0.061     | 15.3      | 0.021      | 0.091     | 23.2      | Pass   |
| 38    | 0.004      | 0.048     | N/A       | 0.011      | 0.073     | N/A       | Pass   |
| 39    | 0.009      | 0.058     | 15.2      | 0.021      | 0.087     | 23.8      | Pass   |
| 40    | 0.005      | 0.046     | N/A       | 0.011      | 0.069     | N/A       | Pass   |

**ZSW-ZB15  
Harmonics – Class-A**

**Test Result: Pass      Source qualification: Normal**

**Current & voltage waveforms**

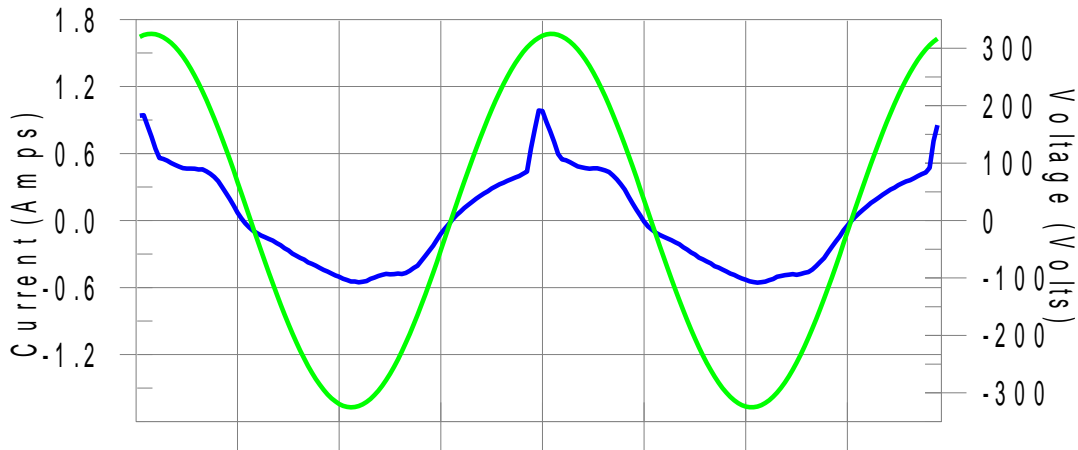

**Harmonics and Class A limit line      European Limits**

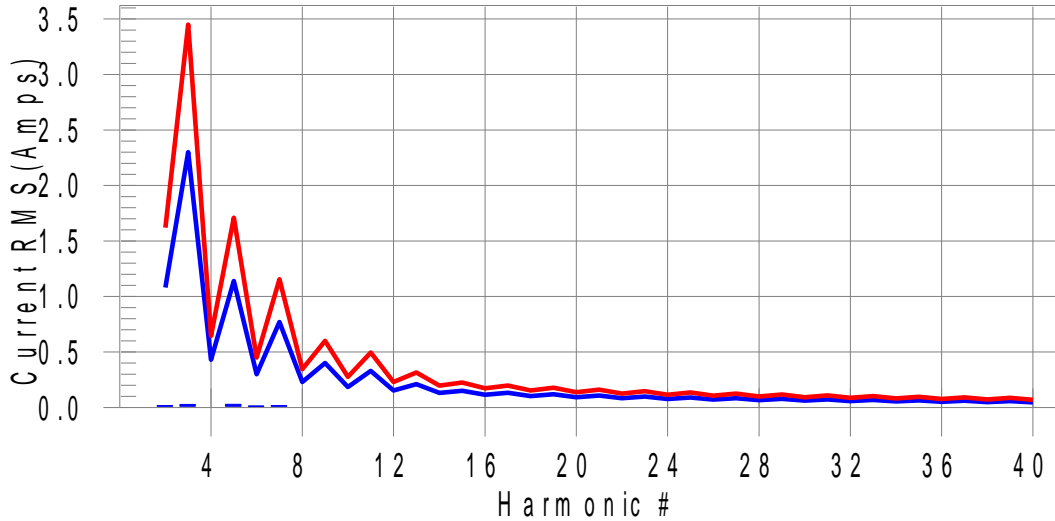

**Test result: Pass      Worst harmonic was #6 with 4.4% of the limit.**

### Current Test Result Summary

Test Result: Pass      Source qualification: Normal  
 THC(A): 0.053      I-THD(%): 12.6      POHC(A): 0.000      POHC Limit(A): 0.251  
 Highest parameter values during test:

|                |        |                |       |
|----------------|--------|----------------|-------|
| V_RMS (Volts): | 230.18 | Frequency(Hz): | 50.00 |
| I_Peak (Amps): | 1.016  | I_RMS (Amps):  | 0.502 |
| I_Fund (Amps): | 0.499  | Crest Factor:  | 2.397 |
| Power (Watts): | 114.4  | Power Factor:  | 0.993 |

| Harm# | Harms(avg) | 100%Limit | %of Limit | Harms(max) | 150%Limit | %of Limit | Status |
|-------|------------|-----------|-----------|------------|-----------|-----------|--------|
| 2     | 0.018      | 1.080     | 1.6       | 0.026      | 1.620     | 1.6       | Pass   |
| 3     | 0.027      | 2.300     | 1.2       | 0.041      | 3.450     | 1.2       | Pass   |
| 4     | 0.010      | 0.430     | 2.3       | 0.017      | 0.645     | 2.7       | Pass   |
| 5     | 0.028      | 1.140     | 2.5       | 0.038      | 1.710     | 2.2       | Pass   |
| 6     | 0.013      | 0.300     | 4.4       | 0.020      | 0.450     | 4.4       | Pass   |
| 7     | 0.017      | 0.770     | 2.2       | 0.021      | 1.155     | 1.8       | Pass   |
| 8     | 0.007      | 0.230     | 3.2       | 0.013      | 0.345     | 3.6       | Pass   |
| 9     | 0.007      | 0.400     | 1.7       | 0.011      | 0.600     | 1.9       | Pass   |
| 10    | 0.007      | 0.184     | 3.9       | 0.012      | 0.276     | 4.2       | Pass   |
| 11    | 0.006      | 0.330     | 1.8       | 0.009      | 0.495     | 1.9       | Pass   |
| 12    | 0.006      | 0.153     | 3.9       | 0.010      | 0.230     | 4.2       | Pass   |
| 13    | 0.005      | 0.210     | 2.6       | 0.008      | 0.315     | 2.6       | Pass   |
| 14    | 0.005      | 0.131     | 3.9       | 0.008      | 0.197     | 3.8       | Pass   |
| 15    | 0.005      | 0.150     | N/A       | 0.007      | 0.225     | N/A       | Pass   |
| 16    | 0.004      | 0.115     | N/A       | 0.006      | 0.173     | N/A       | Pass   |
| 17    | 0.004      | 0.132     | N/A       | 0.005      | 0.198     | N/A       | Pass   |
| 18    | 0.003      | 0.102     | N/A       | 0.004      | 0.153     | N/A       | Pass   |
| 19    | 0.003      | 0.118     | N/A       | 0.003      | 0.178     | N/A       | Pass   |
| 20    | 0.002      | 0.092     | N/A       | 0.002      | 0.138     | N/A       | Pass   |
| 21    | 0.002      | 0.107     | N/A       | 0.002      | 0.161     | N/A       | Pass   |
| 22    | 0.001      | 0.084     | N/A       | 0.002      | 0.125     | N/A       | Pass   |
| 23    | 0.001      | 0.098     | N/A       | 0.001      | 0.147     | N/A       | Pass   |
| 24    | 0.001      | 0.077     | N/A       | 0.001      | 0.115     | N/A       | Pass   |
| 25    | 0.000      | 0.090     | N/A       | 0.001      | 0.135     | N/A       | Pass   |
| 26    | 0.000      | 0.071     | N/A       | 0.001      | 0.107     | N/A       | Pass   |
| 27    | 0.001      | 0.083     | N/A       | 0.001      | 0.125     | N/A       | Pass   |
| 28    | 0.001      | 0.066     | N/A       | 0.001      | 0.099     | N/A       | Pass   |
| 29    | 0.001      | 0.078     | N/A       | 0.001      | 0.116     | N/A       | Pass   |
| 30    | 0.001      | 0.061     | N/A       | 0.001      | 0.092     | N/A       | Pass   |
| 31    | 0.001      | 0.073     | N/A       | 0.001      | 0.109     | N/A       | Pass   |
| 32    | 0.001      | 0.058     | N/A       | 0.001      | 0.086     | N/A       | Pass   |
| 33    | 0.001      | 0.068     | N/A       | 0.001      | 0.102     | N/A       | Pass   |
| 34    | 0.001      | 0.054     | N/A       | 0.001      | 0.081     | N/A       | Pass   |
| 35    | 0.001      | 0.064     | N/A       | 0.001      | 0.096     | N/A       | Pass   |
| 36    | 0.001      | 0.051     | N/A       | 0.001      | 0.077     | N/A       | Pass   |
| 37    | 0.001      | 0.061     | N/A       | 0.001      | 0.091     | N/A       | Pass   |
| 38    | 0.000      | 0.048     | N/A       | 0.001      | 0.073     | N/A       | Pass   |
| 39    | 0.000      | 0.058     | N/A       | 0.001      | 0.087     | N/A       | Pass   |
| 40    | 0.000      | 0.046     | N/A       | 0.001      | 0.069     | N/A       | Pass   |

**ZSW-ZB16  
Harmonics – Class-A**

Test Result: Pass Source qualification: Normal

**Current & voltage waveforms**

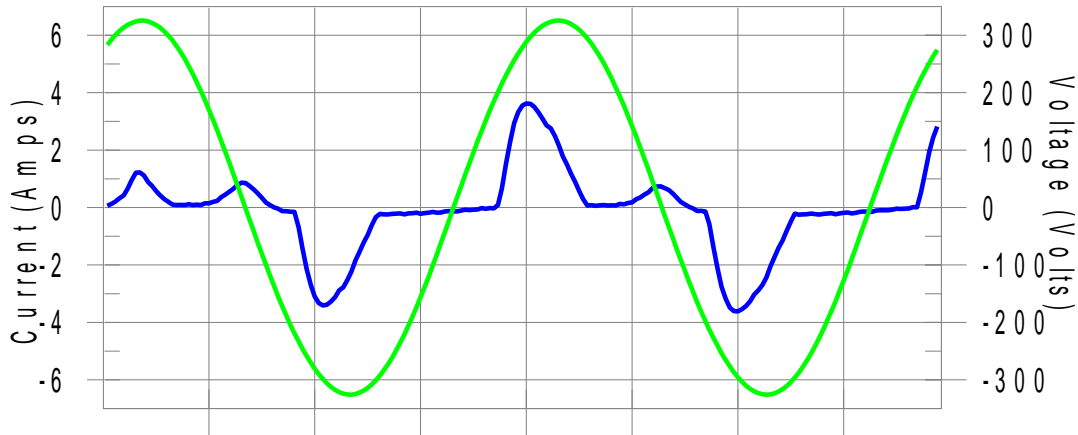

**Harmonics and Class A limit line      European Limits**

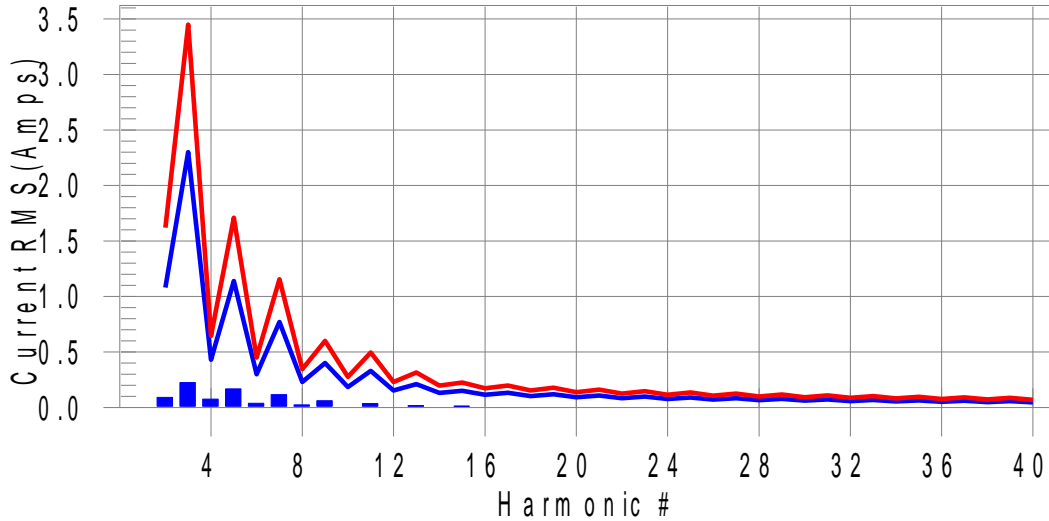

**Test result: Pass Worst harmonic was #4 with 17.5% of the limit.**

### Current Test Result Summary

Test Result: Pass      Source qualification: Normal  
 THC(A): 0.337      I-THD(%): 88.1      POHC(A): 0.000      POHC Limit(A): 0.251  
 Highest parameter values during test:

|                |        |                |       |
|----------------|--------|----------------|-------|
| V_RMS (Volts): | 230.17 | Frequency(Hz): | 50.00 |
| I_Peak (Amps): | 3.647  | I_RMS (Amps):  | 1.085 |
| I_Fund (Amps): | 0.546  | Crest Factor:  | 5.564 |
| Power (Watts): | 122.7  | Power Factor:  | 0.731 |

| Harm# | Harms(avg) | 100%Limit | %of Limit | Harms(max) | 150%Limit | %of Limit | Status |
|-------|------------|-----------|-----------|------------|-----------|-----------|--------|
| 2     | 0.090      | 1.080     | 8.4       | 0.095      | 1.620     | 5.9       | Pass   |
| 3     | 0.225      | 2.300     | 9.8       | 0.375      | 3.450     | 10.9      | Pass   |
| 4     | 0.075      | 0.430     | 17.5      | 0.077      | 0.645     | 11.9      | Pass   |
| 5     | 0.168      | 1.140     | 14.7      | 0.244      | 1.710     | 14.2      | Pass   |
| 6     | 0.038      | 0.300     | 12.6      | 0.040      | 0.450     | 8.8       | Pass   |
| 7     | 0.115      | 0.770     | 15.0      | 0.164      | 1.155     | 14.2      | Pass   |
| 8     | 0.023      | 0.230     | 10.1      | 0.025      | 0.345     | 7.2       | Pass   |
| 9     | 0.061      | 0.400     | 15.2      | 0.070      | 0.600     | 11.7      | Pass   |
| 10    | 0.009      | 0.184     | 4.7       | 0.010      | 0.276     | 3.7       | Pass   |
| 11    | 0.036      | 0.330     | 11.0      | 0.044      | 0.495     | 8.9       | Pass   |
| 12    | 0.005      | 0.153     | N/A       | 0.006      | 0.230     | N/A       | Pass   |
| 13    | 0.017      | 0.210     | 8.0       | 0.025      | 0.315     | 7.8       | Pass   |
| 14    | 0.002      | 0.131     | N/A       | 0.003      | 0.197     | N/A       | Pass   |
| 15    | 0.012      | 0.150     | 8.2       | 0.018      | 0.225     | 8.1       | Pass   |
| 16    | 0.002      | 0.115     | N/A       | 0.003      | 0.173     | N/A       | Pass   |
| 17    | 0.008      | 0.132     | 5.8       | 0.015      | 0.198     | 7.4       | Pass   |
| 18    | 0.002      | 0.102     | N/A       | 0.002      | 0.153     | N/A       | Pass   |
| 19    | 0.006      | 0.118     | 5.4       | 0.013      | 0.178     | 7.1       | Pass   |
| 20    | 0.001      | 0.092     | N/A       | 0.002      | 0.138     | N/A       | Pass   |
| 21    | 0.005      | 0.107     | N/A       | 0.011      | 0.161     | N/A       | Pass   |
| 22    | 0.001      | 0.084     | N/A       | 0.002      | 0.125     | N/A       | Pass   |
| 23    | 0.004      | 0.098     | N/A       | 0.010      | 0.147     | N/A       | Pass   |
| 24    | 0.001      | 0.077     | N/A       | 0.001      | 0.115     | N/A       | Pass   |
| 25    | 0.004      | 0.090     | N/A       | 0.008      | 0.135     | N/A       | Pass   |
| 26    | 0.001      | 0.071     | N/A       | 0.001      | 0.107     | N/A       | Pass   |
| 27    | 0.004      | 0.083     | N/A       | 0.007      | 0.125     | N/A       | Pass   |
| 28    | 0.001      | 0.066     | N/A       | 0.001      | 0.099     | N/A       | Pass   |
| 29    | 0.004      | 0.078     | N/A       | 0.006      | 0.116     | N/A       | Pass   |
| 30    | 0.001      | 0.061     | N/A       | 0.001      | 0.092     | N/A       | Pass   |
| 31    | 0.003      | 0.073     | N/A       | 0.004      | 0.109     | N/A       | Pass   |
| 32    | 0.001      | 0.058     | N/A       | 0.001      | 0.086     | N/A       | Pass   |
| 33    | 0.002      | 0.068     | N/A       | 0.003      | 0.102     | N/A       | Pass   |
| 34    | 0.001      | 0.054     | N/A       | 0.001      | 0.081     | N/A       | Pass   |
| 35    | 0.001      | 0.064     | N/A       | 0.002      | 0.096     | N/A       | Pass   |
| 36    | 0.001      | 0.051     | N/A       | 0.001      | 0.077     | N/A       | Pass   |
| 37    | 0.001      | 0.061     | N/A       | 0.003      | 0.091     | N/A       | Pass   |
| 38    | 0.001      | 0.048     | N/A       | 0.001      | 0.073     | N/A       | Pass   |
| 39    | 0.002      | 0.058     | N/A       | 0.003      | 0.087     | N/A       | Pass   |
| 40    | 0.001      | 0.046     | N/A       | 0.001      | 0.069     | N/A       | Pass   |

**ZSW-ZB13 with Alternative main PCB, synchronous motor and water pump  
Harmonics – Class-A**

Test Result: Pass      Source qualification: Normal

**Current & voltage waveforms**

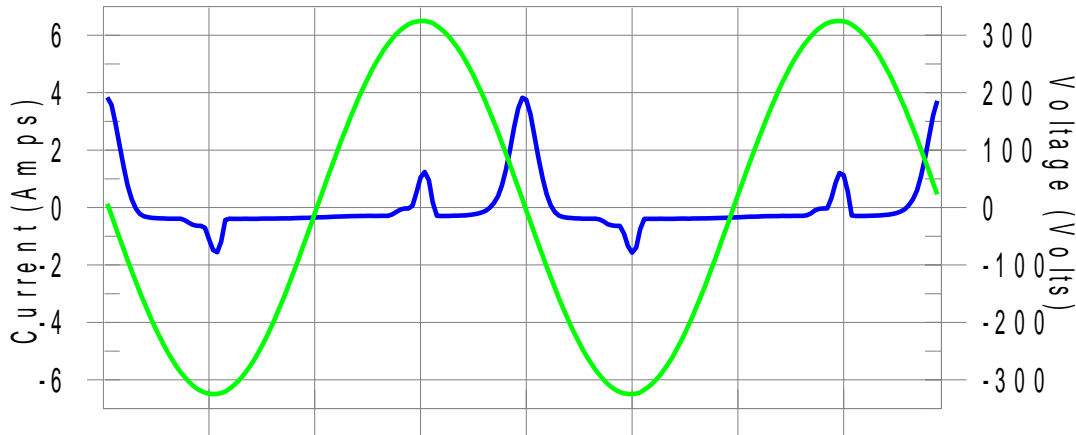

**Harmonics and Class A limit line      European Limits**

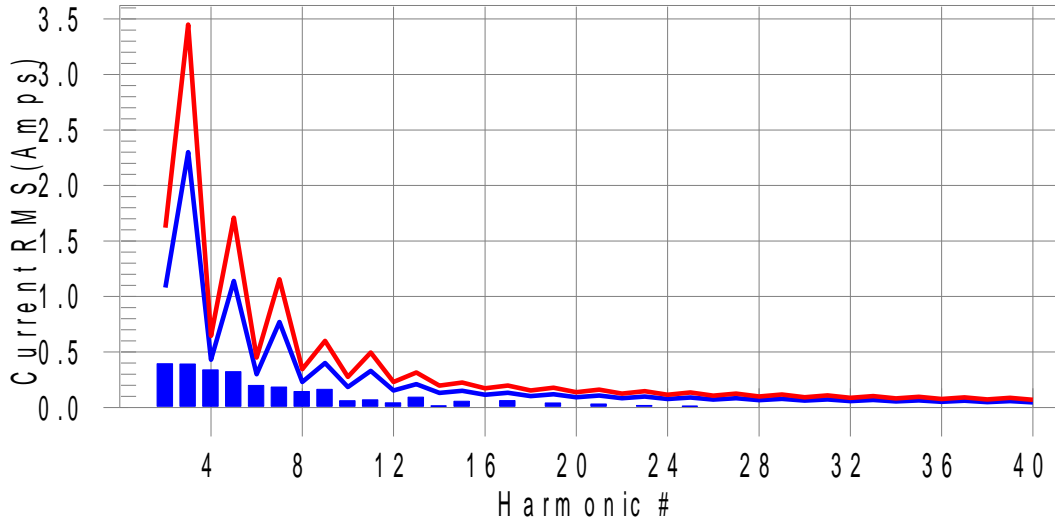

**Test result: Pass      Worst harmonics H4-53.0% of 150% limit, H4-78.8% of 100% limit**

**Current Test Result Summary (Run time)**

Test Result: Pass      Source qualification: Normal  
 THC(A): 0.824    I-THD(%): 153.0    POHC(A): 0.044    POHC Limit(A): 0.251

Highest parameter values during test:

|                |        |                |       |
|----------------|--------|----------------|-------|
| V_RMS (Volts): | 230.19 | Frequency(Hz): | 50.00 |
| I_Peak (Amps): | 3.850  | I_RMS (Amps):  | 1.021 |
| I_Fund (Amps): | 0.538  | Crest Factor:  | 4.069 |
| Power (Watts): | 68.9   | Power Factor:  | 0.301 |

| Harm# | Harms(avg) | 100%Limit | %of Limit | Harms(max) | 150%Limit | %of Limit | Status |
|-------|------------|-----------|-----------|------------|-----------|-----------|--------|
| 2     | 0.394      | 1.080     | 36.4      | 0.399      | 1.620     | 24.6      | Pass   |
| 3     | 0.392      | 2.300     | 17.0      | 0.404      | 3.450     | 11.7      | Pass   |
| 4     | 0.339      | 0.430     | 78.8      | 0.342      | 0.645     | 53.0      | Pass   |
| 5     | 0.323      | 1.140     | 28.3      | 0.360      | 1.710     | 21.0      | Pass   |
| 6     | 0.199      | 0.300     | 66.2      | 0.202      | 0.450     | 45.0      | Pass   |
| 7     | 0.185      | 0.770     | 24.0      | 0.198      | 1.155     | 17.1      | Pass   |
| 8     | 0.144      | 0.230     | 62.5      | 0.145      | 0.345     | 42.0      | Pass   |
| 9     | 0.163      | 0.400     | 40.8      | 0.198      | 0.600     | 33.0      | Pass   |
| 10    | 0.061      | 0.184     | 33.0      | 0.062      | 0.276     | 22.5      | Pass   |
| 11    | 0.069      | 0.330     | 21.0      | 0.093      | 0.495     | 18.8      | Pass   |
| 12    | 0.042      | 0.153     | 27.3      | 0.043      | 0.230     | 18.7      | Pass   |
| 13    | 0.093      | 0.210     | 44.5      | 0.115      | 0.315     | 36.5      | Pass   |
| 14    | 0.014      | 0.131     | 10.8      | 0.015      | 0.197     | 7.6       | Pass   |
| 15    | 0.057      | 0.150     | 37.9      | 0.071      | 0.225     | 31.6      | Pass   |
| 16    | 0.010      | 0.115     | 8.4       | 0.011      | 0.173     | 6.2       | Pass   |
| 17    | 0.061      | 0.132     | 46.4      | 0.068      | 0.198     | 34.5      | Pass   |
| 18    | 0.006      | 0.102     | 5.9       | 0.007      | 0.153     | 4.6       | Pass   |
| 19    | 0.041      | 0.118     | 34.5      | 0.042      | 0.178     | 23.9      | Pass   |
| 20    | 0.001      | 0.092     | N/A       | 0.002      | 0.138     | N/A       | Pass   |
| 21    | 0.031      | 0.107     | 29.4      | 0.032      | 0.161     | 20.2      | Pass   |
| 22    | 0.003      | 0.084     | N/A       | 0.004      | 0.125     | N/A       | Pass   |
| 23    | 0.018      | 0.098     | 18.6      | 0.020      | 0.147     | 13.8      | Pass   |
| 24    | 0.002      | 0.077     | N/A       | 0.003      | 0.115     | N/A       | Pass   |
| 25    | 0.012      | 0.090     | 13.5      | 0.014      | 0.135     | 10.5      | Pass   |
| 26    | 0.003      | 0.071     | N/A       | 0.004      | 0.107     | N/A       | Pass   |
| 27    | 0.008      | 0.083     | 9.9       | 0.011      | 0.125     | 8.4       | Pass   |
| 28    | 0.003      | 0.066     | N/A       | 0.003      | 0.099     | N/A       | Pass   |
| 29    | 0.008      | 0.078     | 10.0      | 0.012      | 0.116     | 10.1      | Pass   |
| 30    | 0.003      | 0.061     | N/A       | 0.003      | 0.092     | N/A       | Pass   |
| 31    | 0.008      | 0.073     | 10.7      | 0.012      | 0.109     | 11.4      | Pass   |
| 32    | 0.002      | 0.058     | N/A       | 0.003      | 0.086     | N/A       | Pass   |
| 33    | 0.008      | 0.068     | 11.3      | 0.011      | 0.102     | 11.0      | Pass   |
| 34    | 0.002      | 0.054     | N/A       | 0.002      | 0.081     | N/A       | Pass   |
| 35    | 0.008      | 0.064     | 12.4      | 0.010      | 0.096     | 10.2      | Pass   |
| 36    | 0.001      | 0.051     | N/A       | 0.002      | 0.077     | N/A       | Pass   |
| 37    | 0.007      | 0.061     | 12.2      | 0.008      | 0.091     | 8.9       | Pass   |
| 38    | 0.001      | 0.048     | N/A       | 0.001      | 0.073     | N/A       | Pass   |
| 39    | 0.006      | 0.058     | 11.0      | 0.007      | 0.087     | 7.8       | Pass   |
| 40    | 0.001      | 0.046     | N/A       | 0.002      | 0.069     | N/A       | Pass   |

#### 4.4 Voltage Changes, Voltage Fluctuations and Flicker

This part is concerned with the limitation of voltage fluctuations and flicker impressed on the public low-voltage system.

##### 4.4.1 Limits

| Value | Limit |
|-------|-------|
| Pst   | 1,0   |
| Plt   | 0,65  |
| dt    | 3,3%  |
| dc    | 3,3%  |
| dmax  | 6,0%  |

##### 4.4.2 Measurement test procedure

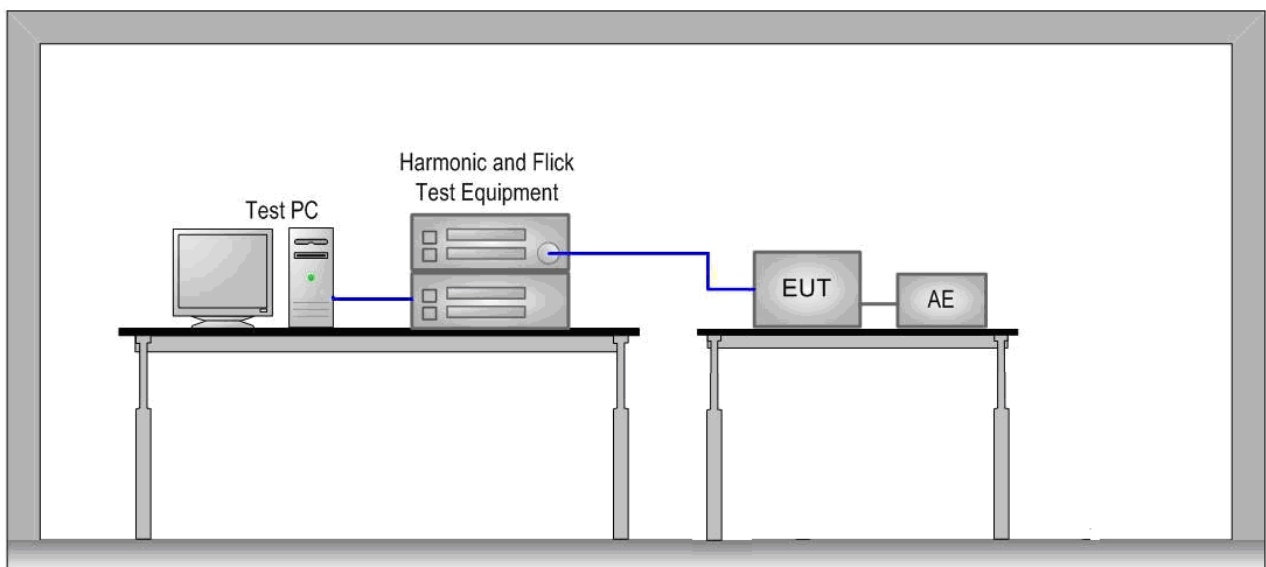

The equipment under test is placed on a wooden table with a height of 0,8 m in the EMC lab. The voltage fluctuations and flicker were measured at the supply terminals of the EUT.

##### 4.4.3 Results

###### ZSW-ZB13

Parameter values recorded during the test:

|                                 |        |                  |            |
|---------------------------------|--------|------------------|------------|
| Vrms at the end of test (Volt): | 229.94 |                  |            |
| T-max (mS):                     | 0      | Test limit (mS): | 500.0 Pass |
| Highest dc (%):                 | 0.00   | Test limit (%):  | 3.30 Pass  |
| Highest dmax (%):               | 0.00   | Test limit (%):  | 4.00 Pass  |
| Highest Pst (10 min. period):   | 0.083  | Test limit:      | 1.000 Pass |
| Highest Plt (2 hr. period):     | 0.036  | Test limit:      | 0.650 Pass |

Test Report No.: EFSH25090011-IE-01-E01-A2

Eurofins Electrical Testing Service (Shanghai) Co., Ltd.  
Building 18, No.2168 Chenhang Highway, Minhang District, Shanghai, China

**ZSW-ZB14**

Parameter values recorded during the test:

|                                 |        |                  |       |      |
|---------------------------------|--------|------------------|-------|------|
| Vrms at the end of test (Volt): | 229.67 |                  |       |      |
| T-max (mS):                     | 0      | Test limit (mS): | 500.0 | Pass |
| Highest dc (%):                 | 0.00   | Test limit (%):  | 3.30  | Pass |
| Highest dmax (%):               | 0.00   | Test limit (%):  | 4.00  | Pass |
| Highest Pst (10 min. period):   | 0.186  | Test limit:      | 1.000 | Pass |
| Highest Plt (2 hr. period):     | 0.028  | Test limit:      | 0.650 | Pass |

**ZSW-ZB15**

Parameter values recorded during the test:

|                                 |        |                  |       |      |
|---------------------------------|--------|------------------|-------|------|
| Vrms at the end of test (Volt): | 229.94 |                  |       |      |
| T-max (mS):                     | 0      | Test limit (mS): | 500.0 | Pass |
| Highest dc (%):                 | 0.00   | Test limit (%):  | 3.30  | Pass |
| Highest dmax (%):               | 0.00   | Test limit (%):  | 4.00  | Pass |
| Highest Pst (10 min. period):   | 0.153  | Test limit:      | 1.000 | Pass |
| Highest Plt (2 hr. period):     | 0.040  | Test limit:      | 0.650 | Pass |

**ZSW-ZB16**

Parameter values recorded during the test:

|                                 |        |                  |       |      |
|---------------------------------|--------|------------------|-------|------|
| Vrms at the end of test (Volt): | 229.94 |                  |       |      |
| T-max (mS):                     | 0      | Test limit (mS): | 500.0 | Pass |
| Highest dc (%):                 | 0.00   | Test limit (%):  | 3.30  | Pass |
| Highest dmax (%):               | 0.00   | Test limit (%):  | 4.00  | Pass |
| Highest Pst (10 min. period):   | 0.259  | Test limit:      | 1.000 | Pass |
| Highest Plt (2 hr. period):     | 0.079  | Test limit:      | 0.650 | Pass |

**ZSW-ZB13 with Alternative main PCB, synchronous motor and water pump**

Parameter values recorded during the test:

|                                 |        |                  |       |      |
|---------------------------------|--------|------------------|-------|------|
| Vrms at the end of test (Volt): | 229.85 |                  |       |      |
| T-max (mS):                     | 0      | Test limit (mS): | 500.0 | Pass |
| Highest dc (%):                 | 0.00   | Test limit (%):  | 3.30  | Pass |
| Highest dmax (%):               | 0.00   | Test limit (%):  | 4.00  | Pass |
| Highest Pst (10 min. period):   | 0.179  | Test limit:      | 1.000 | Pass |
| Highest Plt (2 hr. period):     | 0.045  | Test limit:      | 0.650 | Pass |

## 5 Immunity Test

### 5.1 Performance Criteria Description in Clause 6 of EN IEC 55014-2

|                     |   |
|---------------------|---|
| <b>Criterion A:</b> | The apparatus shall continue to operate as intended during the test. No degradation of performance or loss of function is allowed below a performance level (or permissible loss of performance) specified by the manufacturer, when the apparatus is used as intended. If the minimum performance level or the permissible performance loss is not specified by the manufacturer, then either of these may be derived from the product description and documentation, and from what the user may reasonably expect from the apparatus if used as intended.   |
| <b>Criterion B:</b> | The apparatus shall continue to operate as intended after the test. No degradation of performance or loss of function is allowed below a performance level (or permissible loss of performance) specified by the manufacturer, when the apparatus is used as intended. During the test, degradation of performance is allowed, however. No change of actual operating state or stored data is allowed. If the minimum performance level or the permissible performance loss is not specified by the manufacturer, then either of these may be derived from the product description and documentation and from what the user may reasonably expect from the apparatus if used as intended. |
| <b>Criterion C:</b> | Temporary loss of function is allowed, provided the function is self-recoverable or can be restored by the operation of the controls, or by any operation specified in the instructions for use.  |

### 5.2 Classification of apparatus

|                      |  |
|----------------------|--|
| <b>Category I:</b>   | equipment containing no electronic control circuitry.  |
| <b>Category II:</b>  | mains operated equipment containing electronic control circuitry with no clock frequency higher than 15 MHz.   |
| <b>Category III:</b> | battery operated equipment not included in Category I.<br>This category also includes equipment provided with rechargeable batteries, which can be charged, directly or indirectly, from the mains. Accordingly, this equipment shall also be subjected to the test requirements for mains operated equipment but only when testing the charging function<br>If the equipment can operate its intended functions when connected, directly or indirectly to the mains, then it is not battery operated. Accordingly, it shall be classified as Category II, Category IV or Category V, as applicable, and subjected to the corresponding test requirements when in mains operation. |
| <b>Category IV:</b>  | mains operated equipment containing electronic control circuitry with a highest clock frequency greater than 15 MHz but lower than or equal to 200 MHz.  |
| <b>Category V:</b>   | mains operated equipment containing electronic control circuitry with a highest clock frequency greater than 200 MHz.  |

The EUT (JL-1002, JL-1002-2) belongs to Category I which fulfils the immunity requirement without testing.  
The EUT (GTM-6110) belongs to Category II.

### 5.3 ESD

#### 5.3.1 Test Procedures

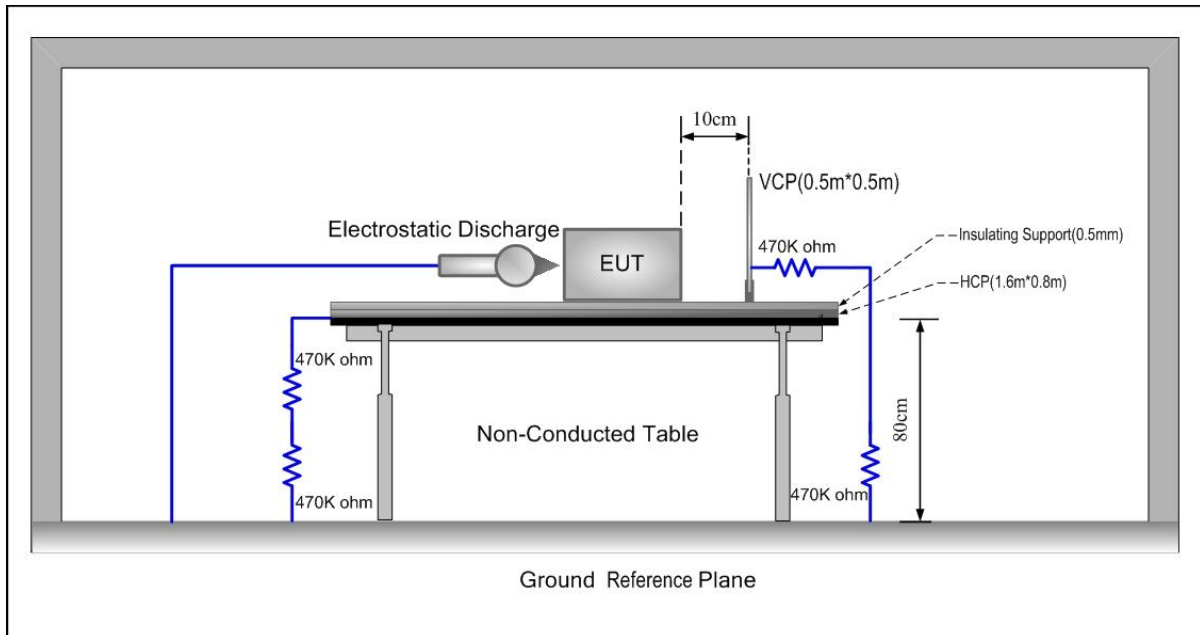

1. Contact discharge was applied only to conductive surfaces of the EUT. Air discharge was applied only to non-conducted surfaces of the EUT.
2. The EUT was put on a 0.8m high wooden table for table-top equipment or 0.1m high for floor standing equipment standing on the ground reference plane (GRP).
3. A horizontal coupling plane (HCP) 1.6m by 0.8m in size was placed on the table, and the EUT with its cables were isolated from the HCP by an insulating support thick than 0.5mm. The VCP 0.5m by 0.5m in size while HCP were constructed from the same material type and thickness as that of the GRP, and connected to the GRP via a 470kΩ resistor at each end. The distance between EUT and any of the other metallic surfaces excepted the GRP, HCP and VCP was greater than 1m.
4. During the contact discharges, the tip of the discharge electrode was touching the EUT before the discharge switch is operated. During the air discharges, the round discharge tip of the discharge electrode was approached as fast as possible to touch the EUT. After each discharge, the ESD generator was removed from the EUT, the generator is then retriggered for a new single discharge. For ungrounded product, a discharge cable with two resistances was used after each discharge to remove remnant electrostatic voltage. 10 times of each polarity single discharge were applied to HCP and VCP.

#### 5.3.2 Results

| Test point        | Table (T)<br>Floor (F) | Contact (C)<br>Air (A) | Voltage<br>(kV) | Number of<br>discharge | Polarity<br>(+ / -) | Opinion |
|-------------------|------------------------|------------------------|-----------------|------------------------|---------------------|---------|
| Air discharge     | T                      | A                      | 8               | 20                     | + / -               | A       |
| Contact discharge | T                      | C                      | 4               | 20                     | + / -               | A       |
| HCP               | T                      | C                      | 4               | 20                     | + / -               | A       |
| VCP               | T                      | C                      | 4               | 20                     | + / -               | A       |

A: no loss of function.

Test Report No.: EFSH25090011-IE-01-E01-A2

Eurofins Electrical Testing Service (Shanghai) Co., Ltd.  
Building 18, No.2168 Chenhang Highway, Minhang District, Shanghai, China

## 5.4 Electrical Fast Transients

### 5.4.1 Measurement procedure

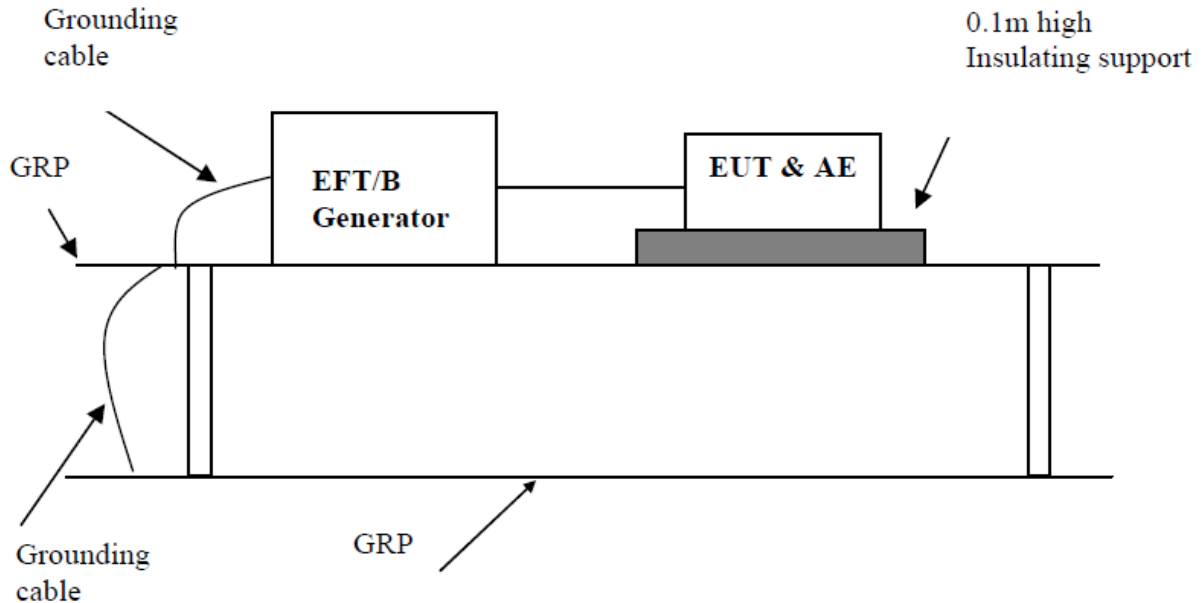

1. The EUT was placed on a ground reference plane (GRP) insulated by an insulating support 0,1 m thick and the GRP was placed on a 0.8m high wooden table for table-top equipment. For floor standing equipment, the EUT was placed on a 0.1m high wooden support above the GRP.
2. The GRP shall project beyond the EUT and the clamp by at least 0.1m on all sides. The distance between the EUT and any other of the metallic surface except the GRP was greater than 0.5m. All cables to the EUT were placed on the insulation support 0.1m above GRP. Cables not subject to EFT was routed as far as possible from cable under test to minimize the coupling between the cables.
3. The length of signal and power cable between the EUT and EFT generator was 0.5m. If the cable is a non-detachable supply cable more than 0.5m, the excess length of this cable shall be folded to avoid a flat coil and situated at a distance of 0.1m above the GRP.

### 5.4.2 Results

| Test port     | Voltage (kV) | Polarity (+ / -) | Duration (s or min) | Waveform Tr / Th | Repetition Frequency (kHz) | Opinion |
|---------------|--------------|------------------|---------------------|------------------|----------------------------|---------|
| AC power line | 1            | +                | 2 min               | 5/50 ns          | 5                          | A       |
| AC power line | 1            | -                | 2 min               | 5/50 ns          | 5                          | A       |

A: no loss of function.

## 5.5 Surge Immunity

### 5.5.1 Measurement procedure

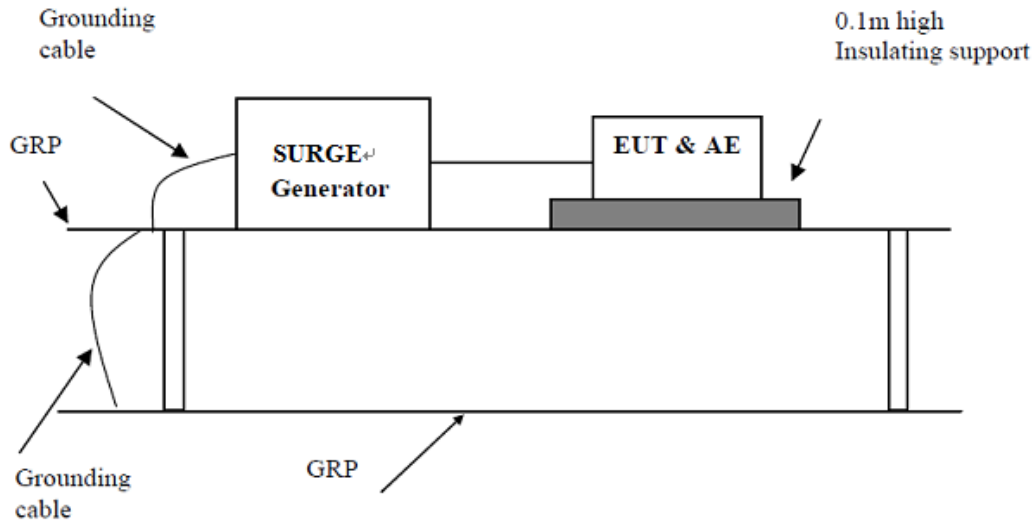

1. The EUT was placed on a ground reference plane (GRP) insulated by an insulating support 0,1 m thick and the GRP was placed on a 0.8m high wooden table for table-top equipment. For floor standing equipment, the EUT was placed on a 0.1m high wooden support above the GRP.
2. The 1,2/50  $\mu$ s surge was to be applied to the EUT power supply terminals via the capacitive coupling network. Decoupling networks were required in order to avoid possible adverse effects on equipment not under test that may be powered by the same lines and to provide sufficient decoupling impedance to the surge wave so that the specified wave may be applied on the lines under test.
3. The positive pulses are applied 90° relative to the phase angle of the a.c. line voltage to the equipment under test, and the negative pulses are applied 270° relative to the phase angle of the a.c. line voltage to the equipment under test.

### 5.5.2 Results

| Test mode     | Polarity (+ / -) | Voltage (kV) | Waveform Tr / Th | Number of pulses | Opinion |
|---------------|------------------|--------------|------------------|------------------|---------|
| Line to line  | + / -            | 1            | 1.2/50 $\mu$ s   | 5                | A       |
| Line to earth | + / -            | 2            | 1.2/50 $\mu$ s   | 5                | A       |

A: no loss of function.

## 5.6 Injected currents (RF continues conducted)

### 5.6.1 Measurement procedure

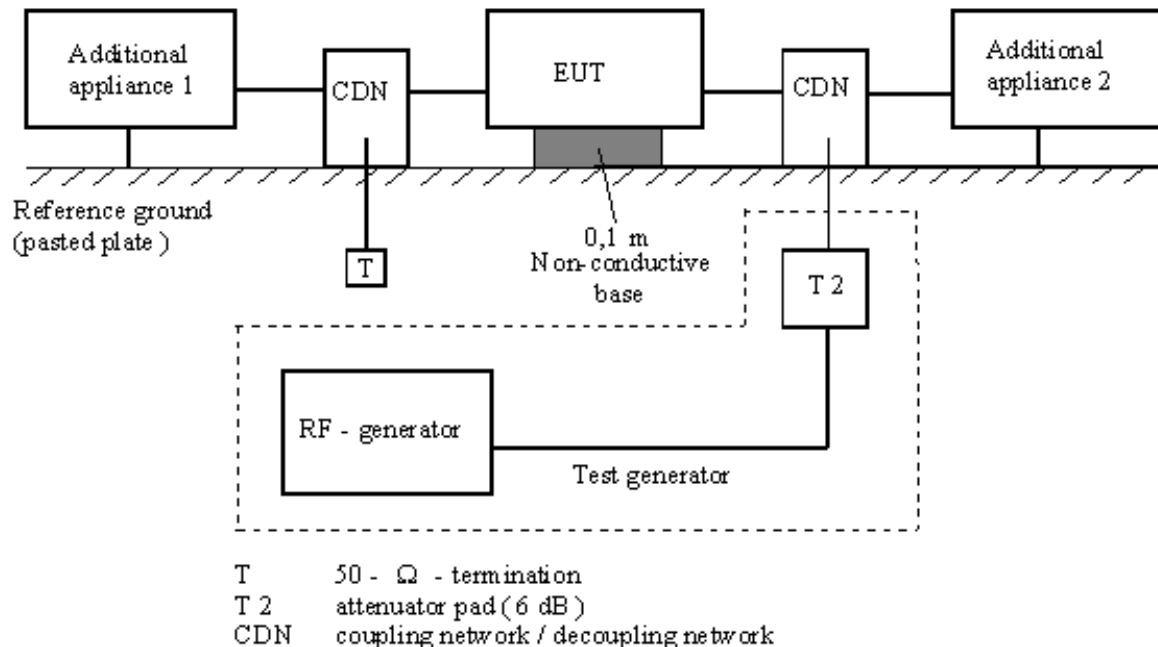

1. The EUT was placed on an insulating support of 0.1m height above a ground reference Plane, arranged and connected to satisfy its functional requirement. All cables exiting the EUT was supported at a height of at least 30 mm above the ground reference plane.
2. The coupling and decoupling devices were required, they were located between 0,1 m and 0,3 m from the EUT. This distance was to be measured horizontally from the projection of the EUT on to the ground reference plane to the coupling and decoupling device.
3. The frequency range was swept from 150 kHz to 230 MHz, using the signal levels established during the setting process, and with the disturbance signal 80 % amplitude modulated with a 1 kHz sine wave, pausing to adjust the RF signal level or to change coupling devices as necessary. Where the frequency was swept incrementally, the step size does not exceed 1 % of the preceding frequency value. The dwell time of the amplitude modulated carrier at each frequency was not less than the time necessary for the EUT to be exercised and to respond, and was not less than 3s.

### 5.6.2 Results

| Test port     | Voltage (e.m.f.) | Modulation   | Frequency Range   | Opinion |
|---------------|------------------|--------------|-------------------|---------|
| AC power line | 3V               | 80% AM 1 kHz | 150 kHz - 230 MHz | A       |

A: no loss of function.

## 5.7 Voltage dips and Interruption

### 5.7.1 Measurement procedure

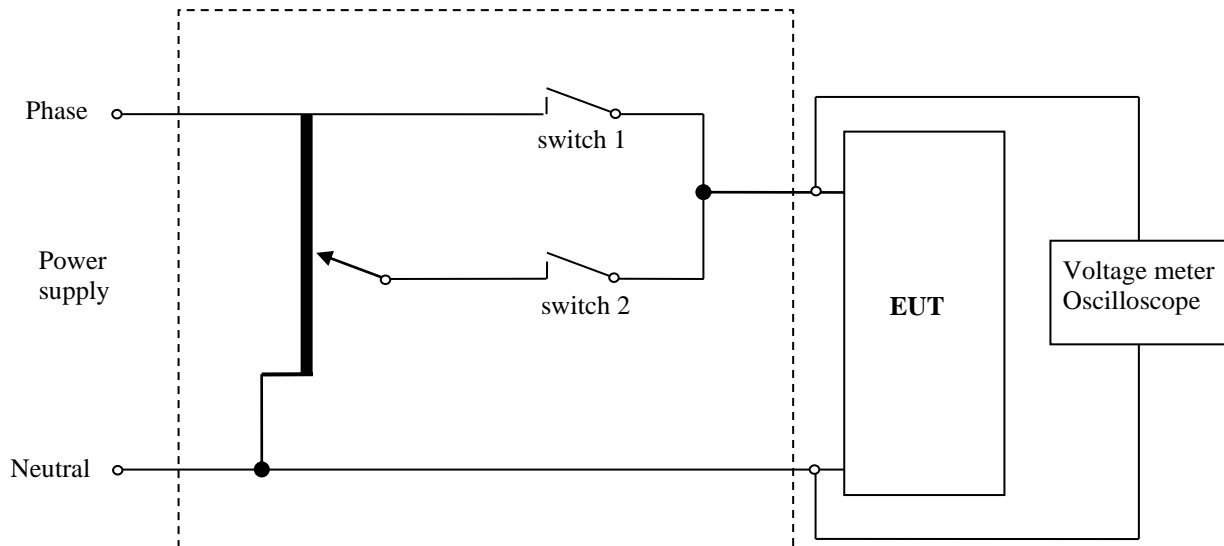

1. The EUT was placed on a ground reference plane (GRP) insulated by an insulating support 0,1 m thick and the GRP was placed on a 0.8m high wooden table for table-top equipment. For floor standing equipment, the EUT was placed on a 0.1m high wooden support above the GRP.
2. The test was performed with the EUT connected to the test generator with the shortest power supply cable as specified by the EUT manufacturer. Voltage change shall occur at zero crossing.
3. The EUT was tested for each selected combination of test level and duration with a sequence of three dips /interruptions with intervals of 10 s minimum. Each representative mode of operation was tested.

### 5.7.2 Results

| Reduction of supply voltage of | Voltage in % (in V) | Duration in parts of period (in ms) | Opinion |
|--------------------------------|---------------------|-------------------------------------|---------|
| interruption                   | 0 % (0V)            | 0,5 (10 ms)                         | A       |
| 60 %                           | 40 % (92 V)         | 10 (200 ms)                         | B       |
| 30 %                           | 70 % (161 V)        | 25 (500 ms)                         | B       |

A: no loss of function.

B: the appliance could not work normally during the test, but it would recover after test.

## 6 Test Setup Photos

Harmonic & Flicker



Conducted Emission



---

Test Report No.: EFSH25090011-IE-01-E01-A2

Eurofins Electrical Testing Service (Shanghai) Co., Ltd.  
Building 18, No.2168 Chenhang Highway, Minhang District, Shanghai, China

Disturbance power



ESD



Electrical Fast Transients, Surge & Dips



Injected currents (RF continues conducted)

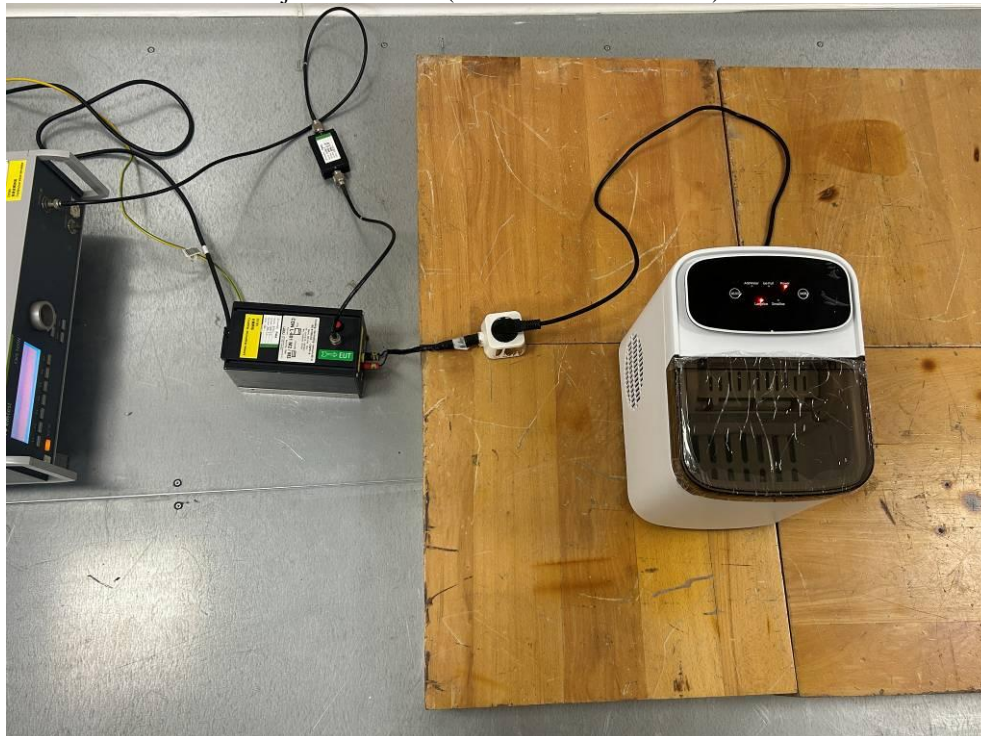

---

Test Report No.: EFSH25090011-IE-01-E01-A2

Eurofins Electrical Testing Service (Shanghai) Co., Ltd.  
Building 18, No.2168 Chenhang Highway, Minhang District, Shanghai, China

## 7 EUT Photos

Photo 1

Description: Overall view of ZSW-ZB13

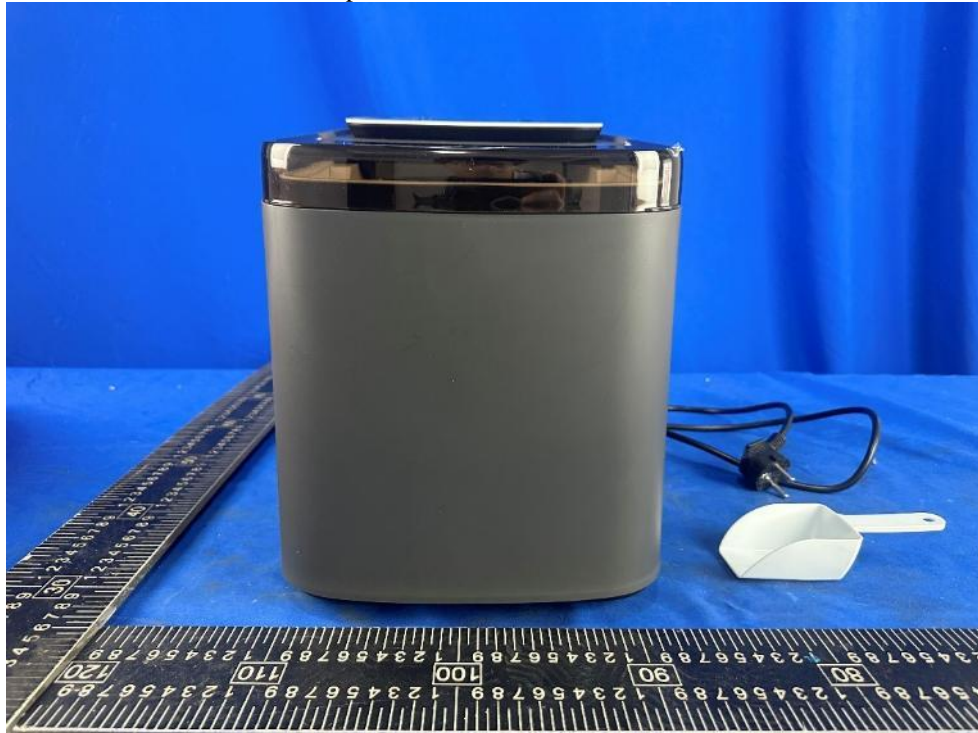

Photo 2

Description: Overall view of ZSW-ZB13



---

Test Report No.: EFSH25090011-IE-01-E01-A2

---

Eurofins Electrical Testing Service (Shanghai) Co., Ltd.  
Building 18, No.2168 Chenhang Highway, Minhang District, Shanghai, China

Photo 3

Description: Overall view of ZSW-ZB13



Photo 4

Description: Overall view of ZSW-ZB13

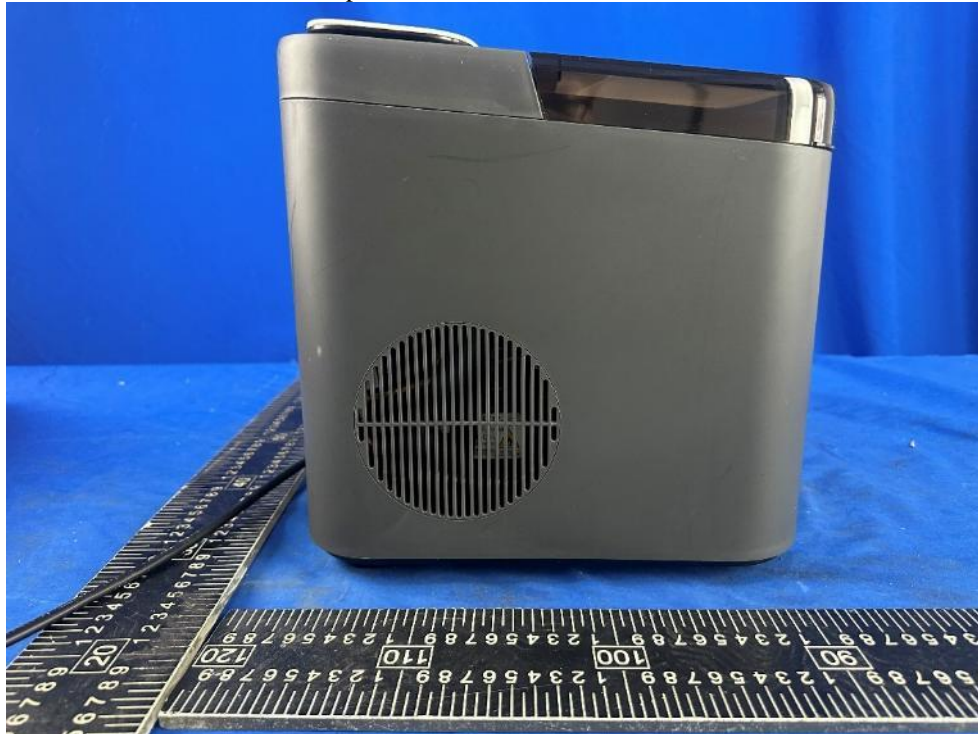

---

Test Report No.: EFSH25090011-IE-01-E01-A2

---

Eurofins Electrical Testing Service (Shanghai) Co., Ltd.  
Building 18, No.2168 Chenhang Highway, Minhang District, Shanghai, China

Photo 5

Description: Overall view of ZSW-ZB13



Photo 6

Description: Overall view of ZSW-ZB13



Photo 7

Description: Knob view of ZSW-ZB13

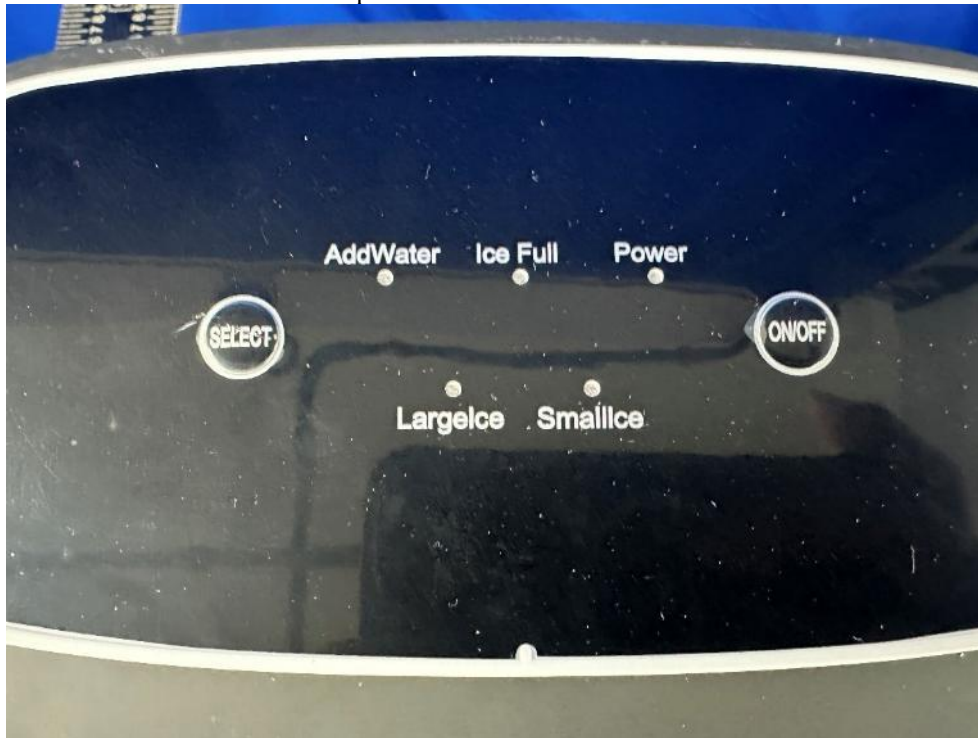

Photo 8

Description: Internal view of ZSW-ZB13



---

Test Report No.: EFSH25090011-IE-01-E01-A2

---

Eurofins Electrical Testing Service (Shanghai) Co., Ltd.  
Building 18, No.2168 Chenhang Highway, Minhang District, Shanghai, China

Photo 9

Description: Internal view of ZSW-ZB13



Photo 10

Description: Internal view of ZSW-ZB13



---

Test Report No.: EFSH25090011-IE-01-E01-A2

---

Eurofins Electrical Testing Service (Shanghai) Co., Ltd.  
Building 18, No.2168 Chenhang Highway, Minhang District, Shanghai, China

Photo 11

Description: Internal view of ZSW-ZB13



Photo 12

Description: Internal view of ZSW-ZB13

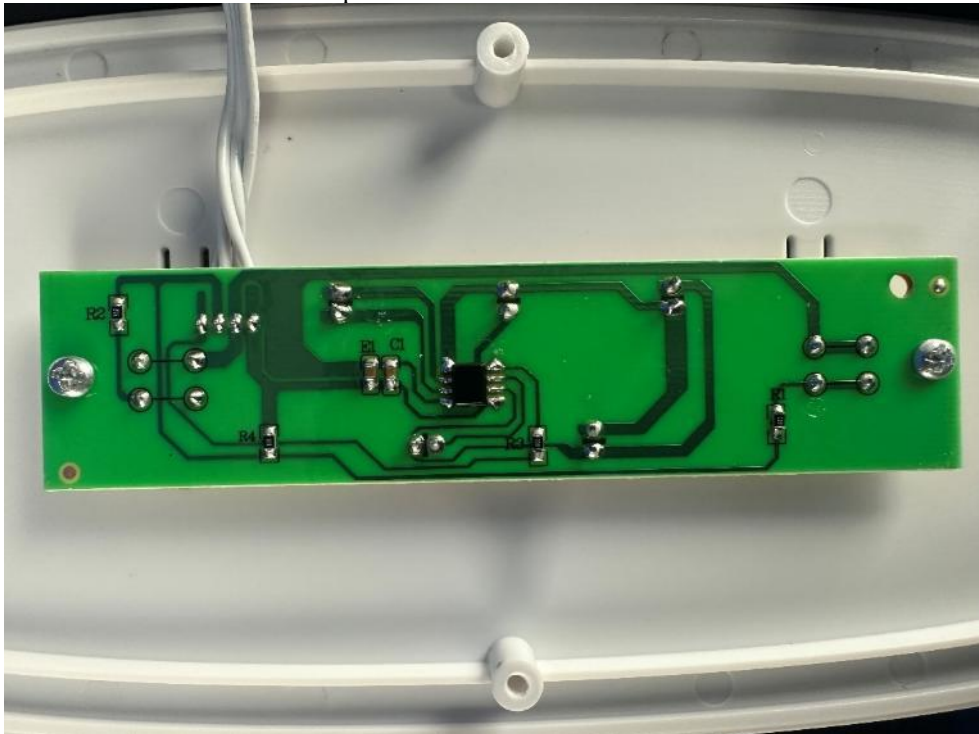

---

Test Report No.: EFSH25090011-IE-01-E01-A2

Eurofins Electrical Testing Service (Shanghai) Co., Ltd.  
Building 18, No.2168 Chenhang Highway, Minhang District, Shanghai, China

Photo 13

Description: Internal view of ZSW-ZB13

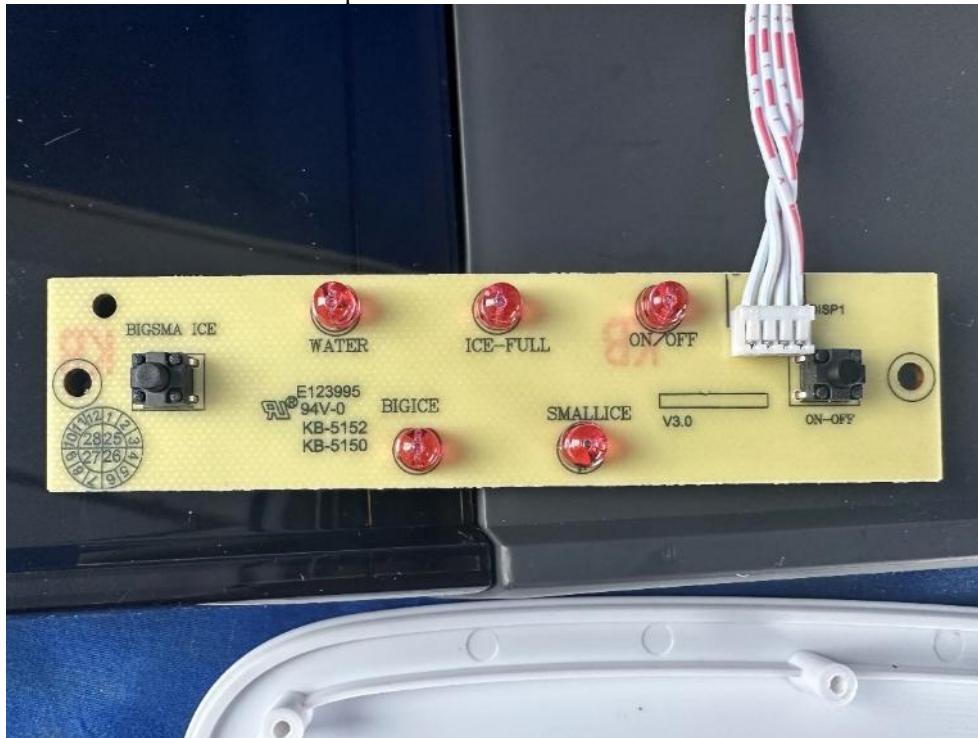

Photo 14

Description: Internal view of ZSW-ZB13

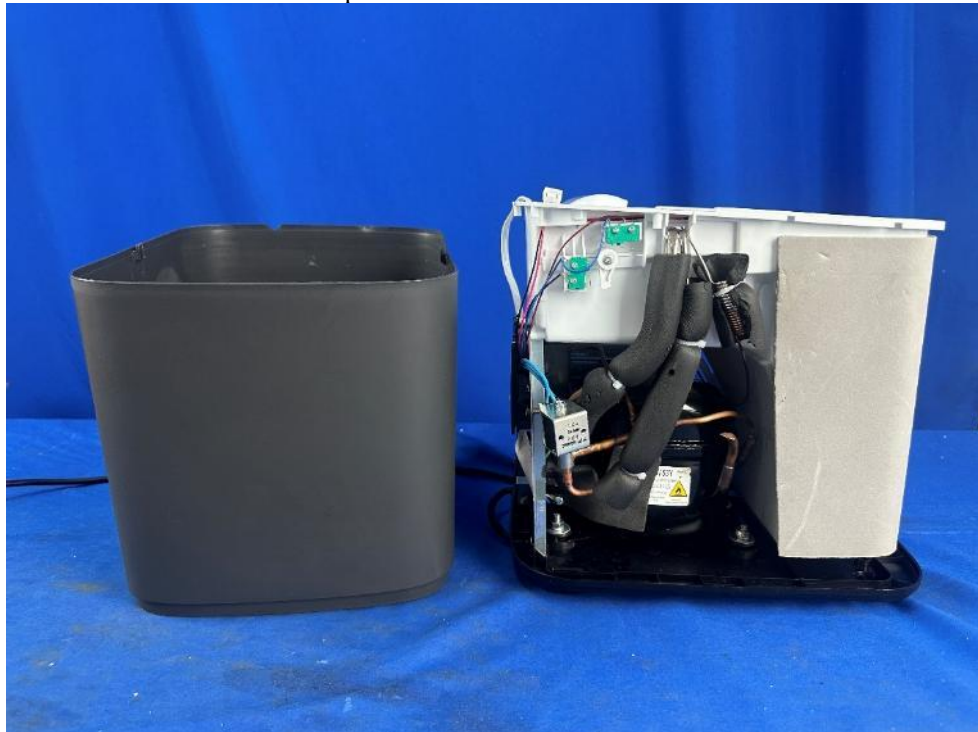

Photo 15

Description: Internal view of ZSW-ZB13



Photo 16

Description: Internal view of ZSW-ZB13

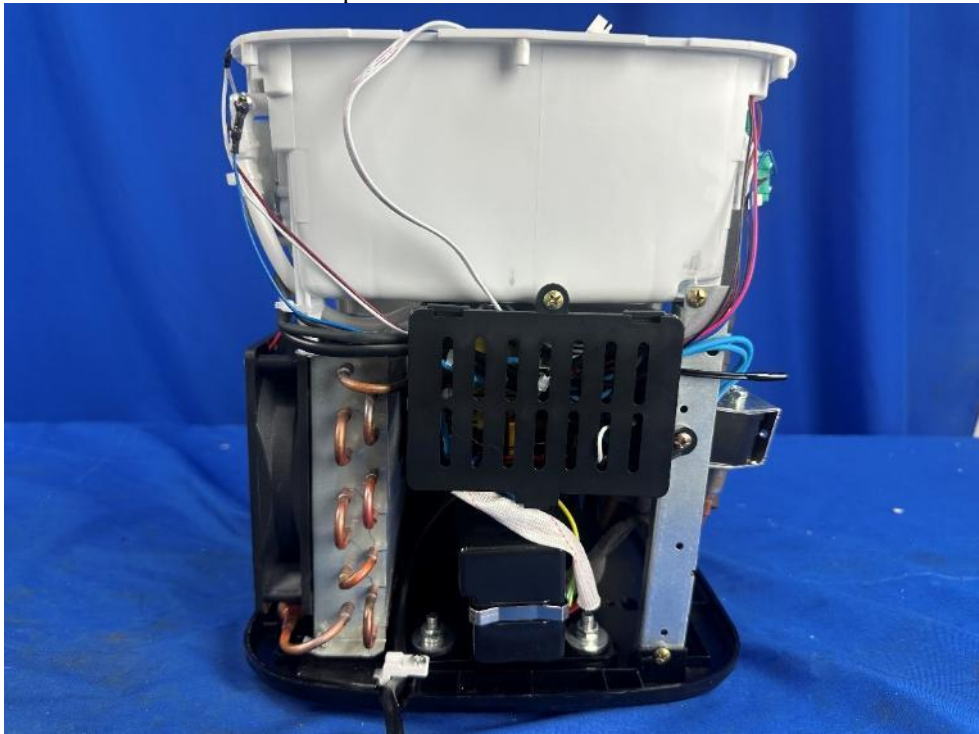

Photo 17

Description: Internal view of ZSW-ZB13



Photo 18

Description: Internal view of ZSW-ZB13



---

Test Report No.: EFSH25090011-IE-01-E01-A2

---

Eurofins Electrical Testing Service (Shanghai) Co., Ltd.  
Building 18, No.2168 Chenhang Highway, Minhang District, Shanghai, China

Photo 19

Description: Internal view of ZSW-ZB13

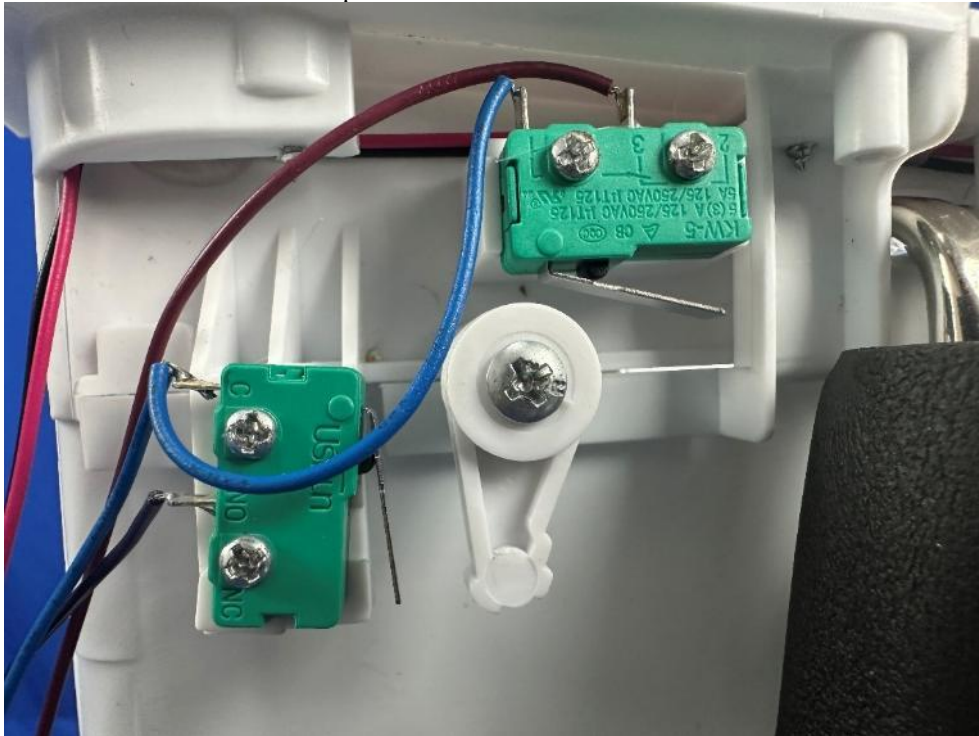

Photo 20

Description: Internal view of ZSW-ZB13



---

Test Report No.: EFSH25090011-IE-01-E01-A2

Eurofins Electrical Testing Service (Shanghai) Co., Ltd.  
Building 18, No.2168 Chenhang Highway, Minhang District, Shanghai, China

Photo 21

Description: Internal view of ZSW-ZB13, ZSW-ZB14

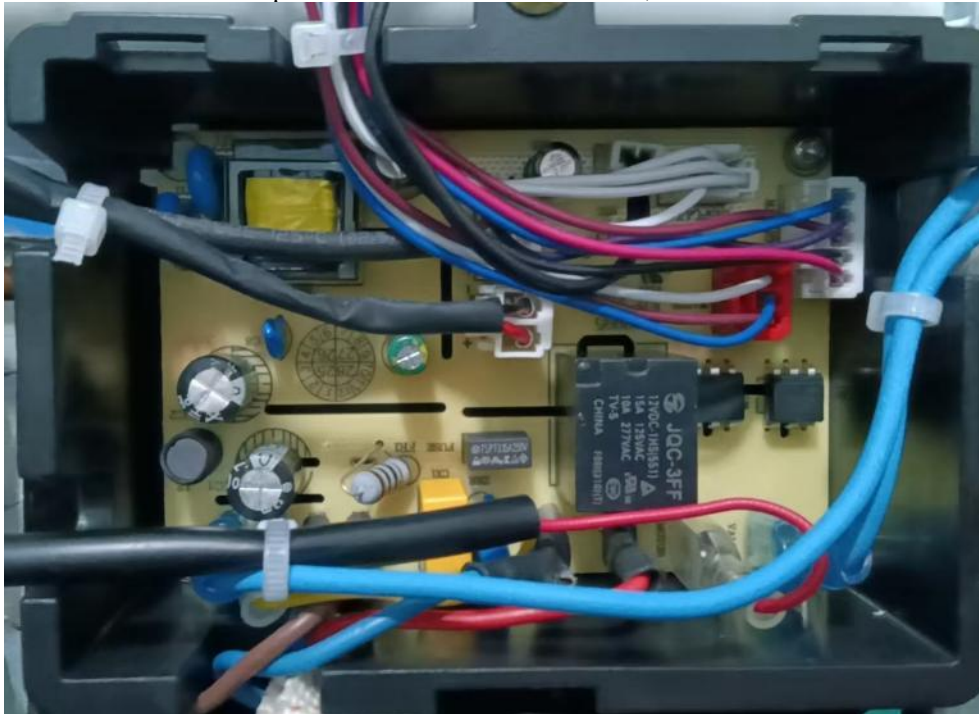

Photo 22

Description: Internal view of ZSW-ZB13, ZSW-ZB14

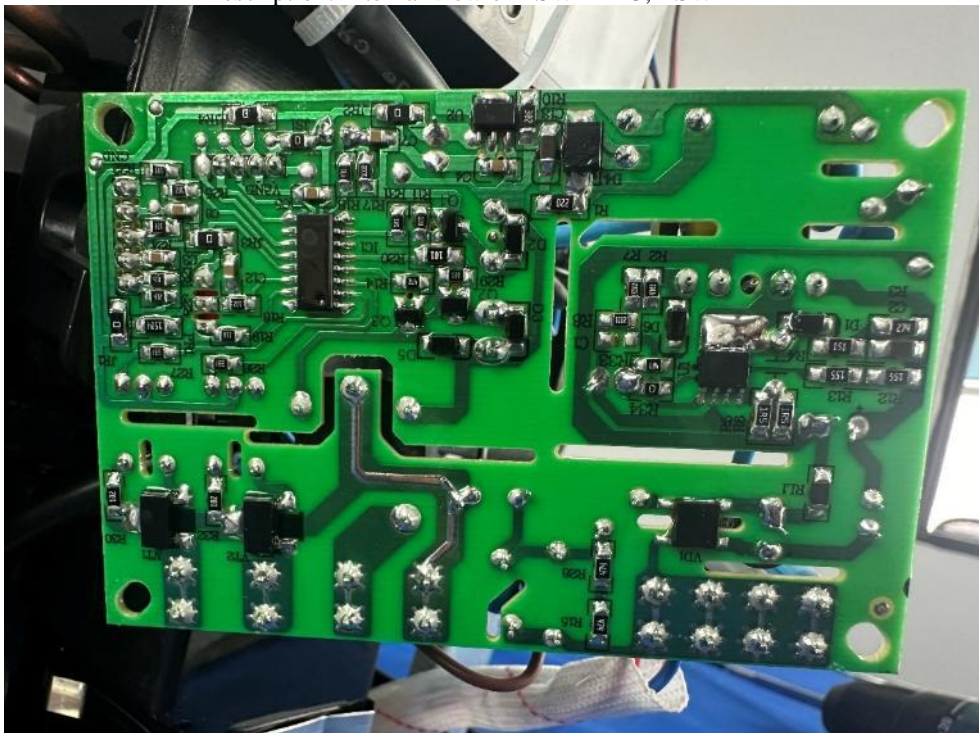

Photo 23

Description: Internal view of ZSW-ZB13

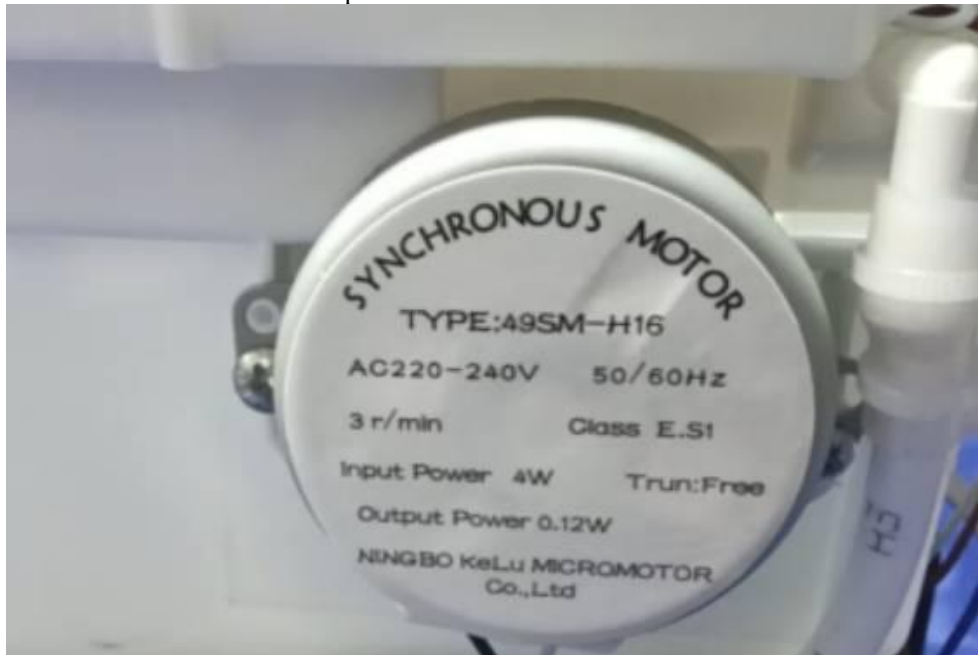

Photo 24

Description: Internal view of ZSW-ZB13



---

Test Report No.: EFSH25090011-IE-01-E01-A2

---

Eurofins Electrical Testing Service (Shanghai) Co., Ltd.  
Building 18, No.2168 Chenhang Highway, Minhang District, Shanghai, China

Photo 25

Description: Earthing view of all models



Photo 26

Description: Overall view of ZSW-ZB14



---

Test Report No.: EFSH25090011-IE-01-E01-A2

---

Eurofins Electrical Testing Service (Shanghai) Co., Ltd.  
Building 18, No.2168 Chenhang Highway, Minhang District, Shanghai, China

Photo 27

Description: Overall view of ZSW-ZB14



Photo 28

Description: Overall view of ZSW-ZB14



Photo 29

Description: Overall view of ZSW-ZB14

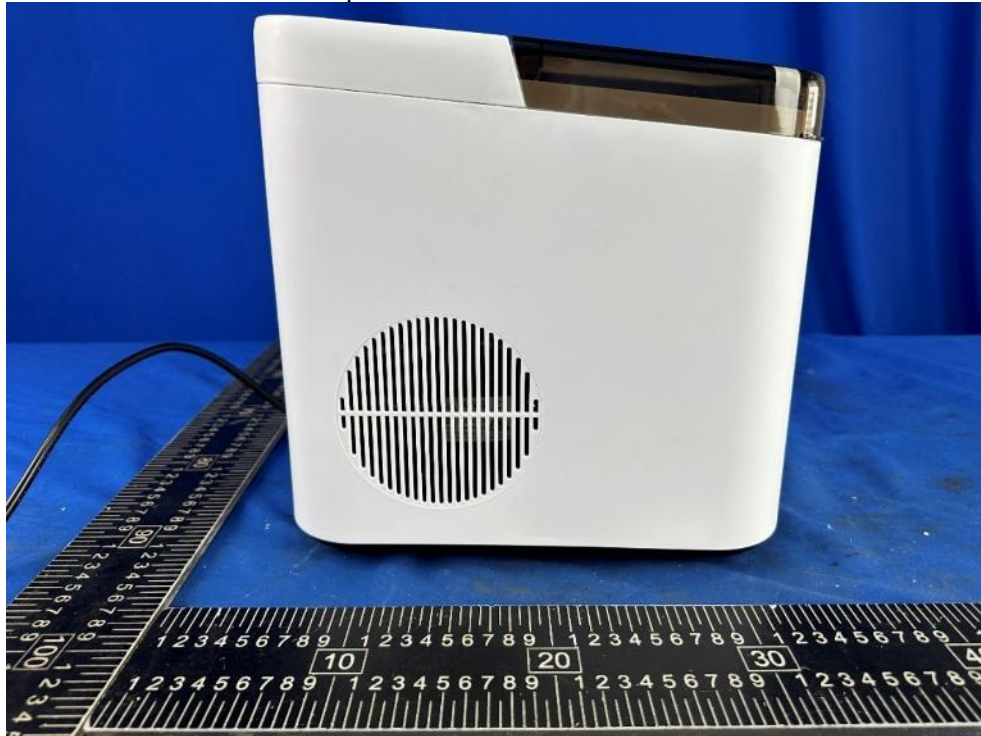

Photo 30

Description: Overall view of ZSW-ZB14

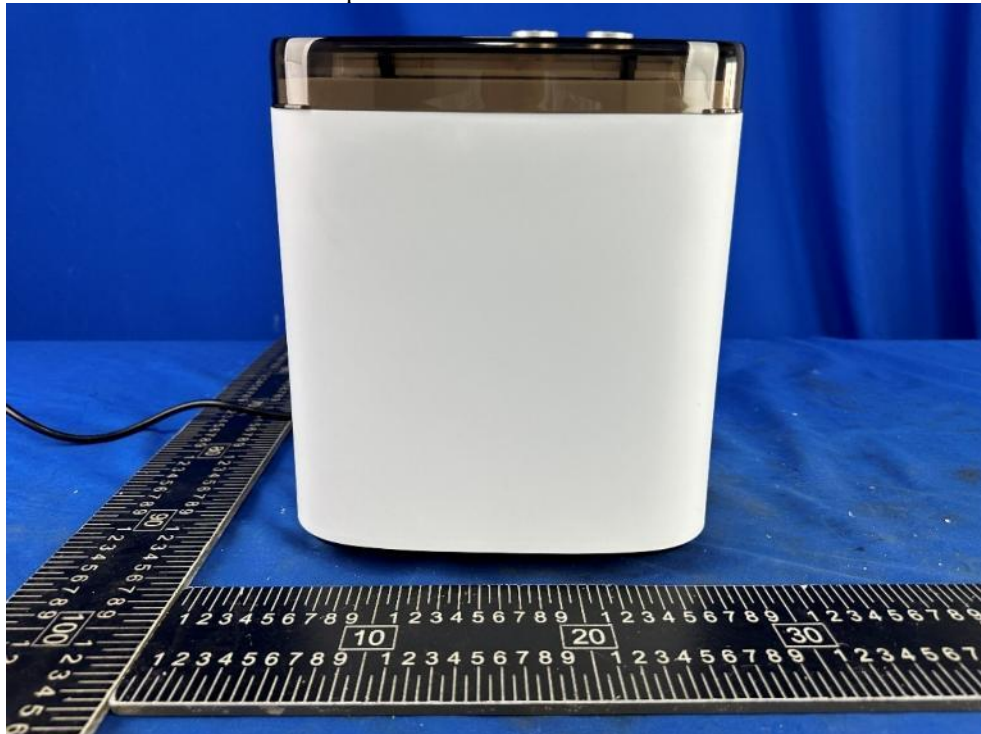

Photo 31

Description: Overall view of ZSW-ZB14



Photo 32

Description: Knob view of ZSW-ZB14



Test Report No.: EFSH25090011-IE-01-E01-A2

Eurofins Electrical Testing Service (Shanghai) Co., Ltd.  
Building 18, No.2168 Chenhang Highway, Minhang District, Shanghai, China

Photo 33

Description: Internal view of ZSW-ZB14



Photo 34

Description: Internal view of ZSW-ZB14



---

Test Report No.: EFSH25090011-IE-01-E01-A2

---

Eurofins Electrical Testing Service (Shanghai) Co., Ltd.  
Building 18, No.2168 Chenhang Highway, Minhang District, Shanghai, China

Photo 35

Description: Internal view of ZSW-ZB14



Photo 36

Description: Internal view of ZSW-ZB14



Photo 37

Description: Internal view of ZSW-ZB14

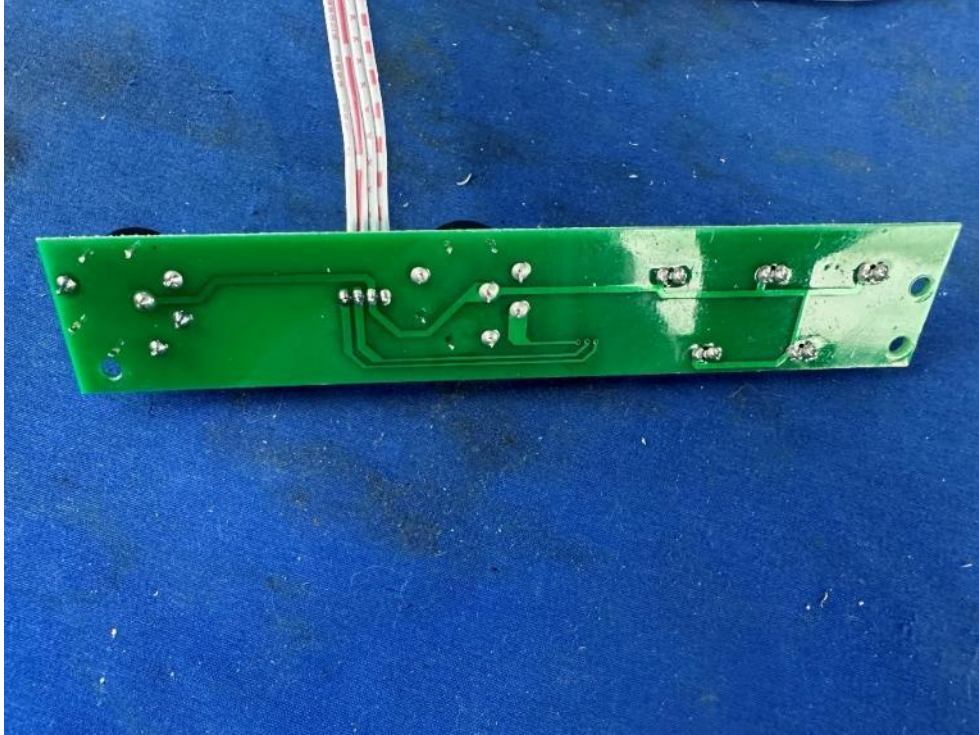
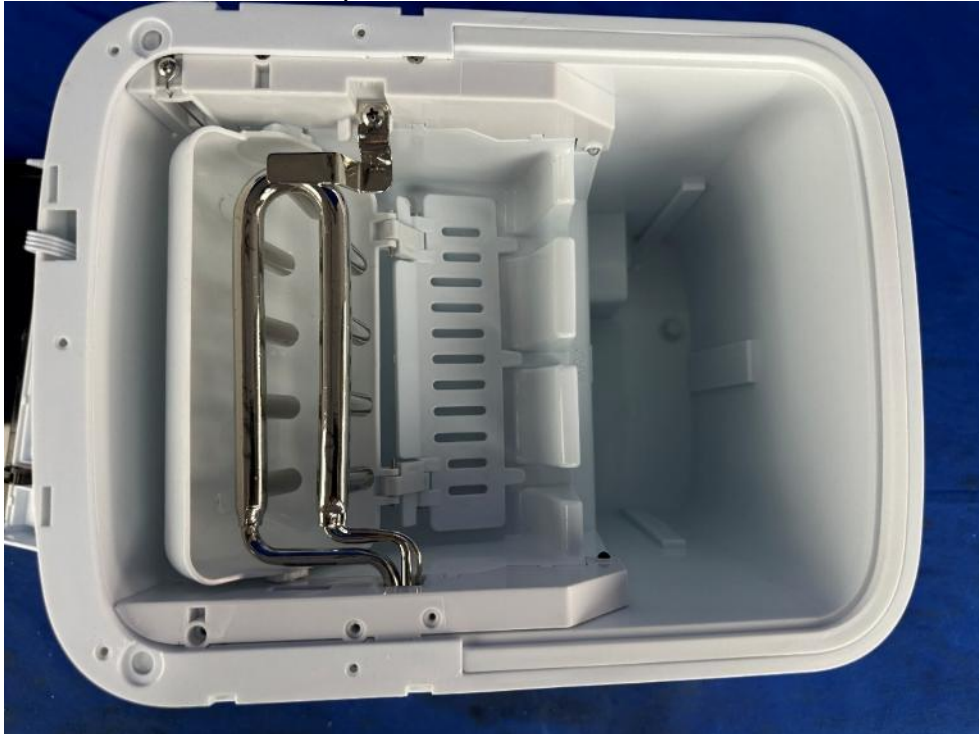

Photo 38

Description: Internal view of ZSW-ZB14



---

Test Report No.: EFSH25090011-IE-01-E01-A2

Eurofins Electrical Testing Service (Shanghai) Co., Ltd.  
Building 18, No.2168 Chenhang Highway, Minhang District, Shanghai, China

Photo 39

Description: Internal view of ZSW-ZB14



Photo 40

Description: Internal view of ZSW-ZB14



---

Test Report No.: EFSH25090011-IE-01-E01-A2

Eurofins Electrical Testing Service (Shanghai) Co., Ltd.  
Building 18, No.2168 Chenhang Highway, Minhang District, Shanghai, China

Photo 41

Description: Internal view of ZSW-ZB14

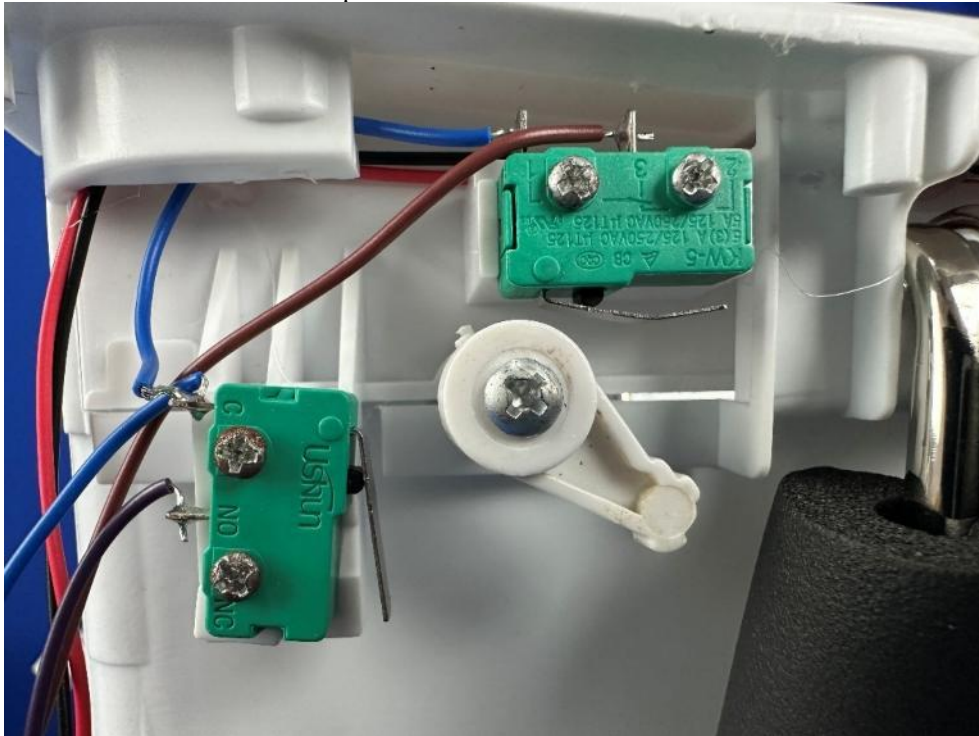

Photo 42

Description: Internal view of ZSW-ZB14



Test Report No.: EFSH25090011-IE-01-E01-A2

Eurofins Electrical Testing Service (Shanghai) Co., Ltd.  
Building 18, No.2168 Chenhang Highway, Minhang District, Shanghai, China

Photo 43

Description: Internal view of ZSW-ZB14

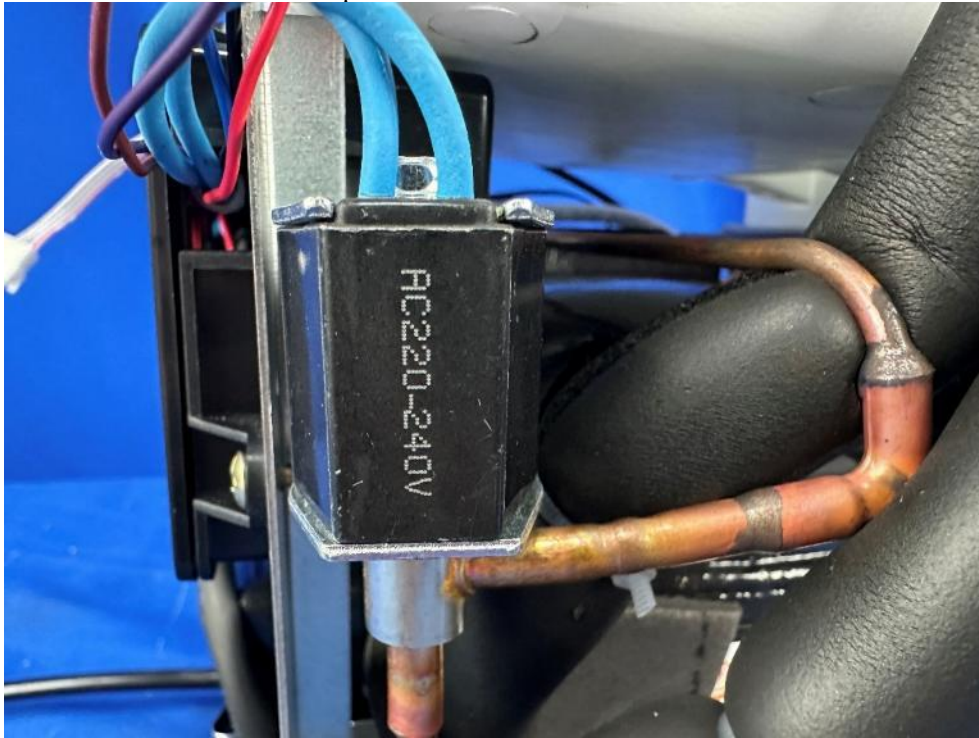
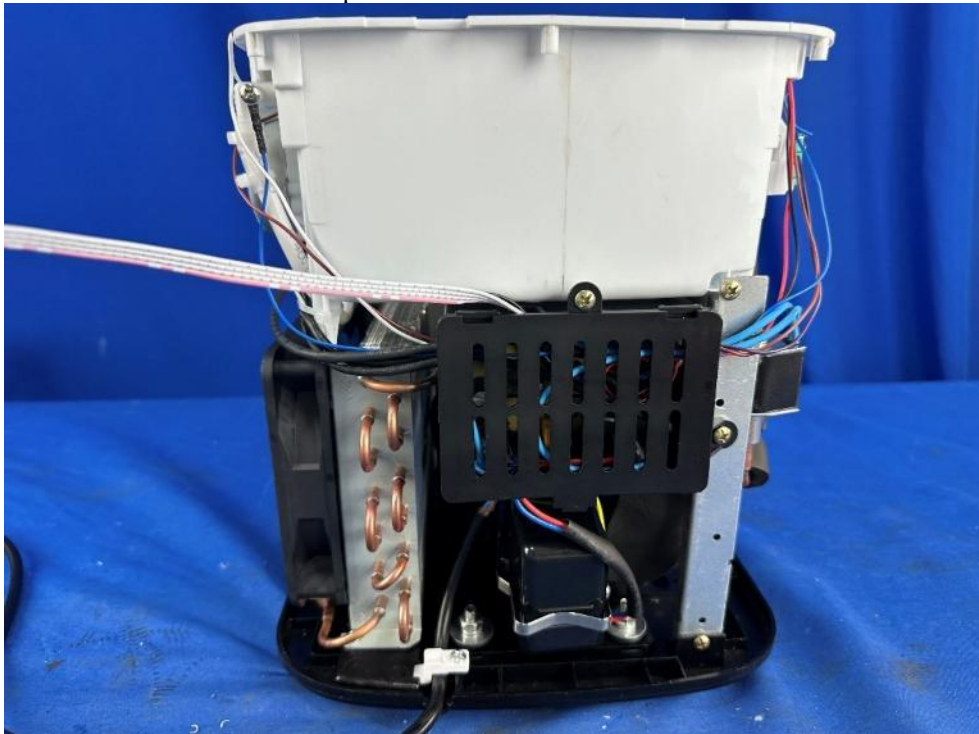

Photo 44

Description: Internal view of ZSW-ZB14



---

Test Report No.: EFSH25090011-IE-01-E01-A2

---

Eurofins Electrical Testing Service (Shanghai) Co., Ltd.  
Building 18, No.2168 Chenhang Highway, Minhang District, Shanghai, China

Photo 45

Description: Internal view of ZSW-ZB14



Photo 46

Description: Internal view of ZSW-ZB14



---

Test Report No.: EFSH25090011-IE-01-E01-A2

---

Eurofins Electrical Testing Service (Shanghai) Co., Ltd.  
Building 18, No.2168 Chenhang Highway, Minhang District, Shanghai, China

Photo 47

Description: Internal view of ZSW-ZB14



Photo 48

Description: Internal view of ZSW-ZB14



---

Test Report No.: EFSH25090011-IE-01-E01-A2

---

Eurofins Electrical Testing Service (Shanghai) Co., Ltd.  
Building 18, No.2168 Chenhang Highway, Minhang District, Shanghai, China

Photo 49

Description: Overall view of ZSW-ZB15

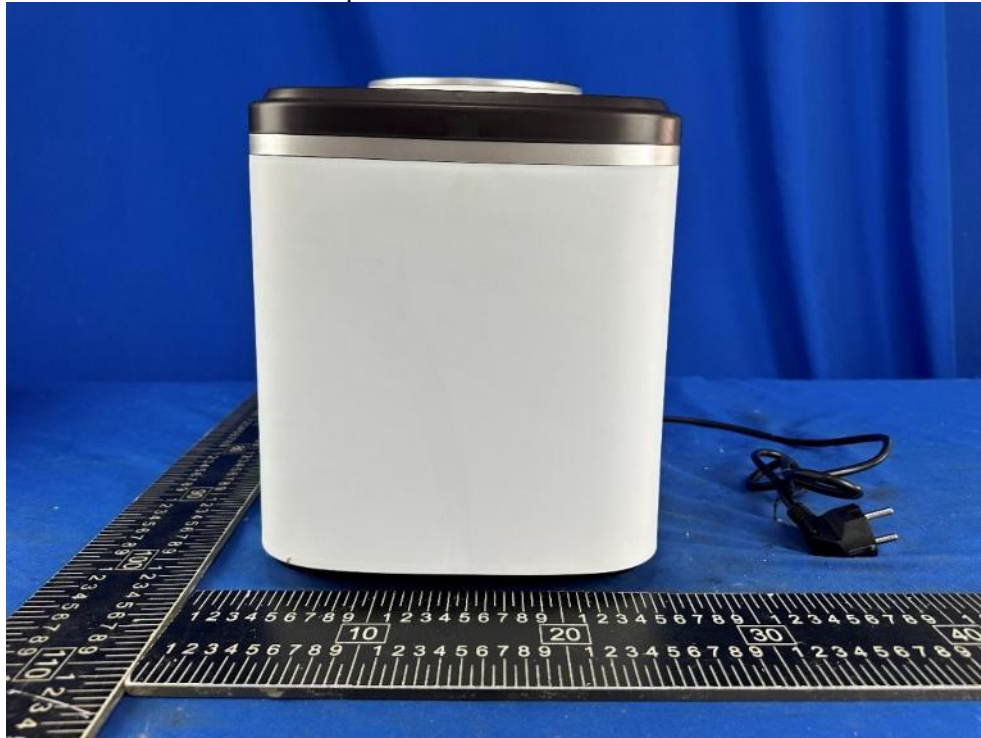

Photo 50

Description: Overall view of ZSW-ZB15



Photo 51

Description: Overall view of ZSW-ZB15

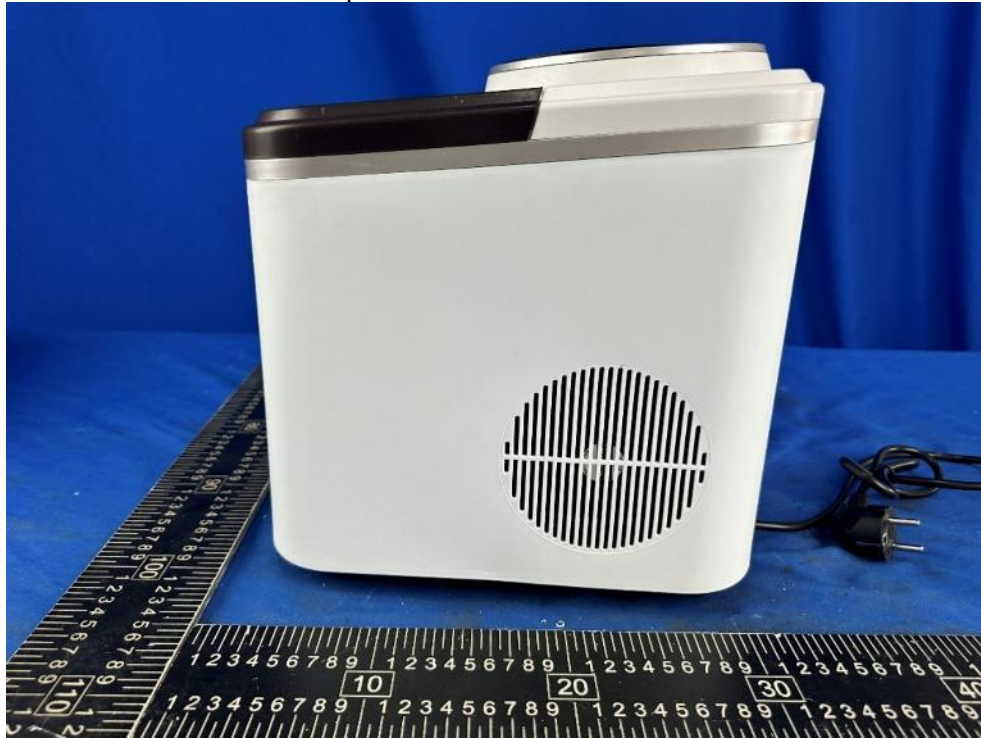

Photo 52

Description: Overall view of ZSW-ZB15



---

Test Report No.: EFSH25090011-IE-01-E01-A2

---

Eurofins Electrical Testing Service (Shanghai) Co., Ltd.  
Building 18, No.2168 Chenhang Highway, Minhang District, Shanghai, China

Photo 53

Description: Overall view of ZSW-ZB15



Photo 54

Description: Overall view of ZSW-ZB15

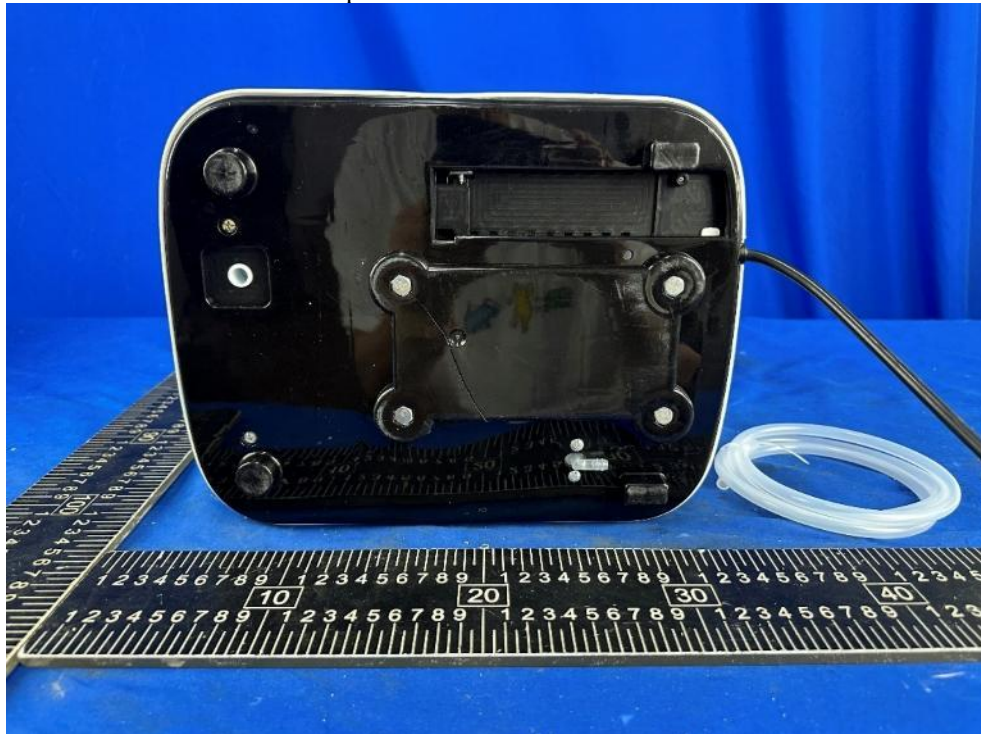

Photo 55

Description: Internal view of ZSW-ZB15

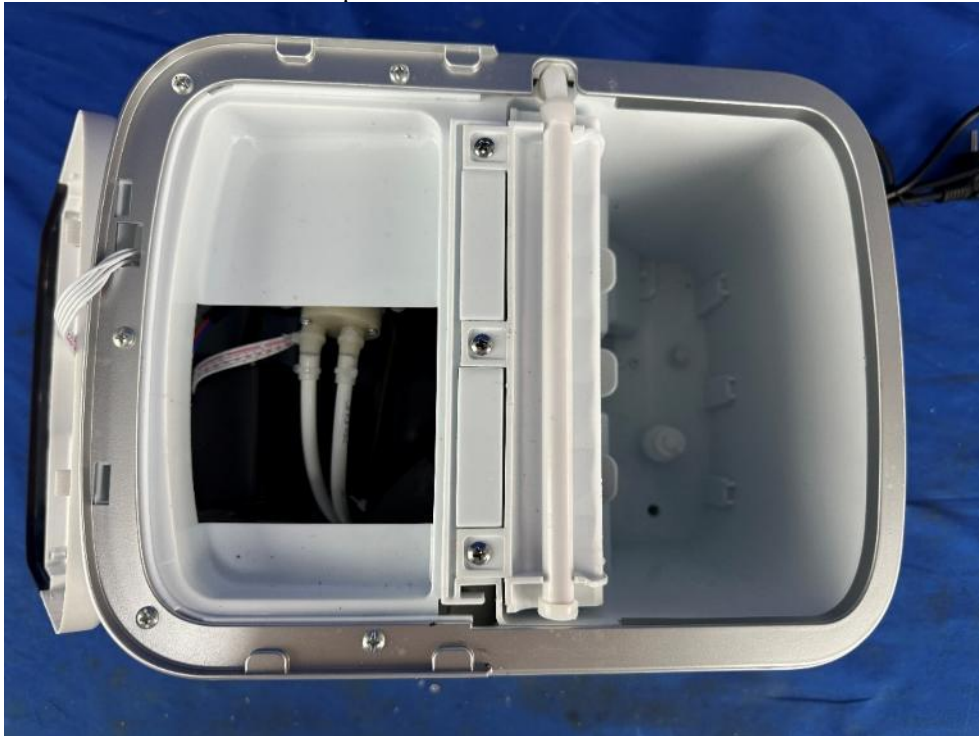
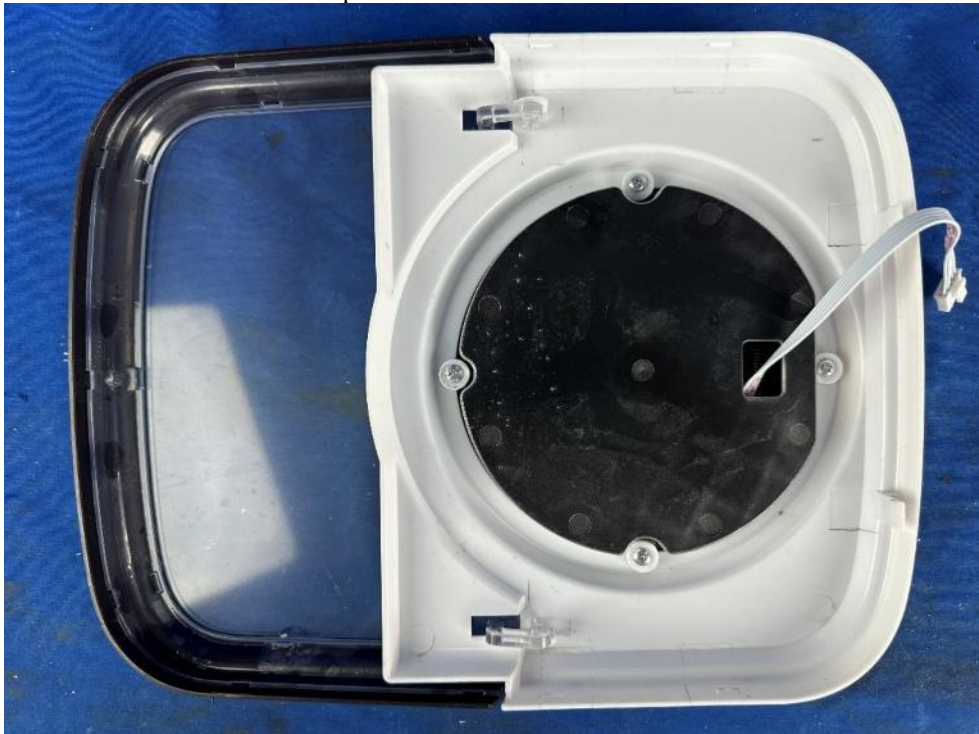

Photo 56

Description: Internal view of ZSW-ZB15



---

Test Report No.: EFSH25090011-IE-01-E01-A2

---

Eurofins Electrical Testing Service (Shanghai) Co., Ltd.  
Building 18, No.2168 Chenhang Highway, Minhang District, Shanghai, China

Photo 57

Description: Internal view of ZSW-ZB15



Photo 58

Description: Internal view of ZSW-ZB15



Photo 59

Description: Internal view of ZSW-ZB15

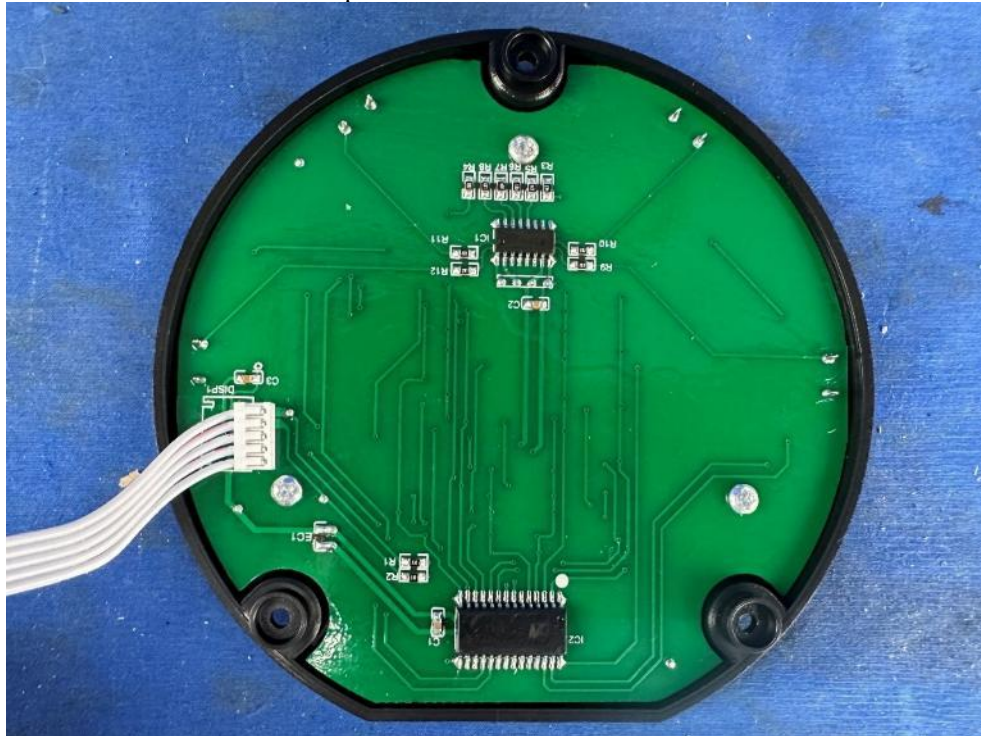

Photo 60

Description: Internal view of ZSW-ZB15

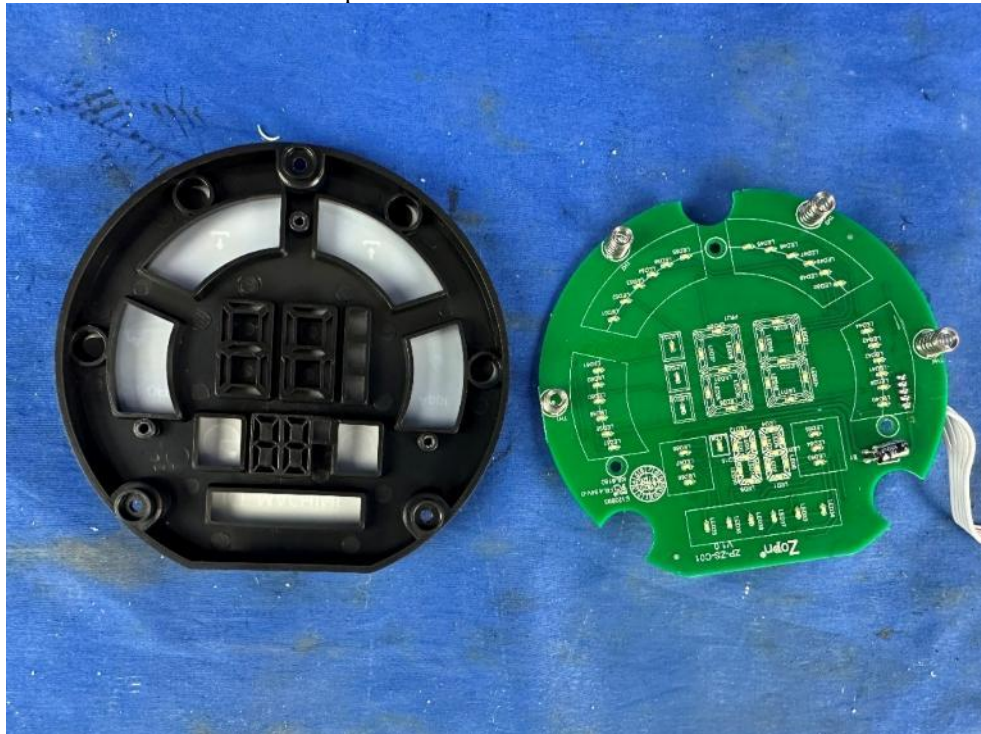

Photo 61

Description: Internal view of ZSW-ZB15

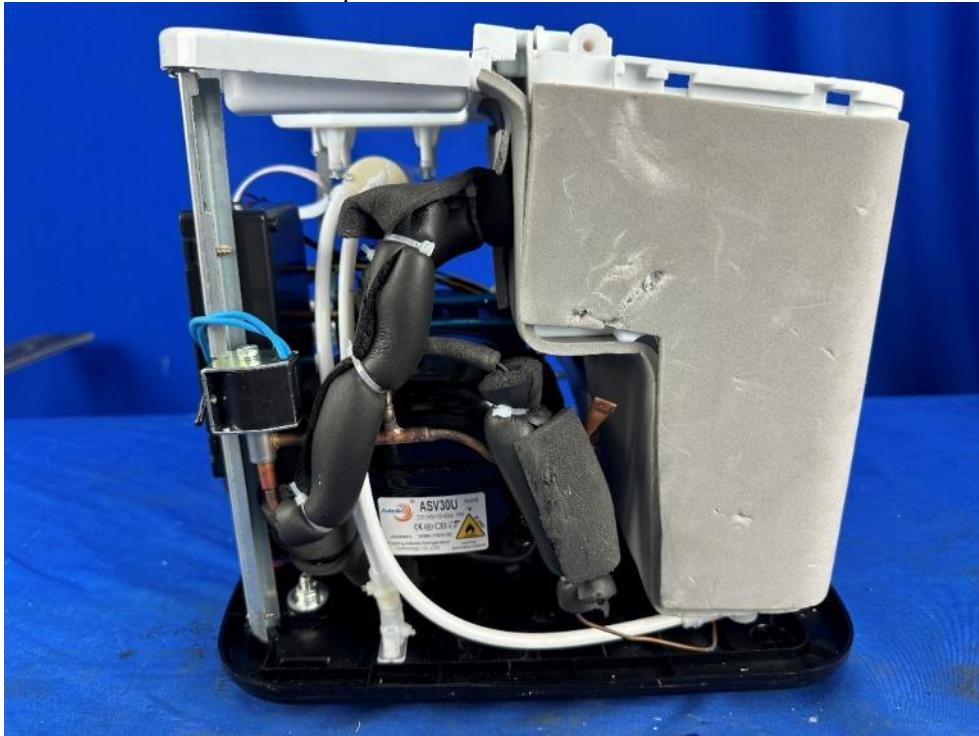

Photo 62

Description: Internal view of ZSW-ZB15



---

Test Report No.: EFSH25090011-IE-01-E01-A2

---

Eurofins Electrical Testing Service (Shanghai) Co., Ltd.  
Building 18, No.2168 Chenhang Highway, Minhang District, Shanghai, China

Photo 63

Description: Internal view of ZSW-ZB15



Photo 64

Description: Internal view of ZSW-ZB15



Photo 65

Description: Internal view of ZSW-ZB15



Photo 66

Description: Internal view of ZSW-ZB15, ZSW-ZB16, ZSW-ZB17

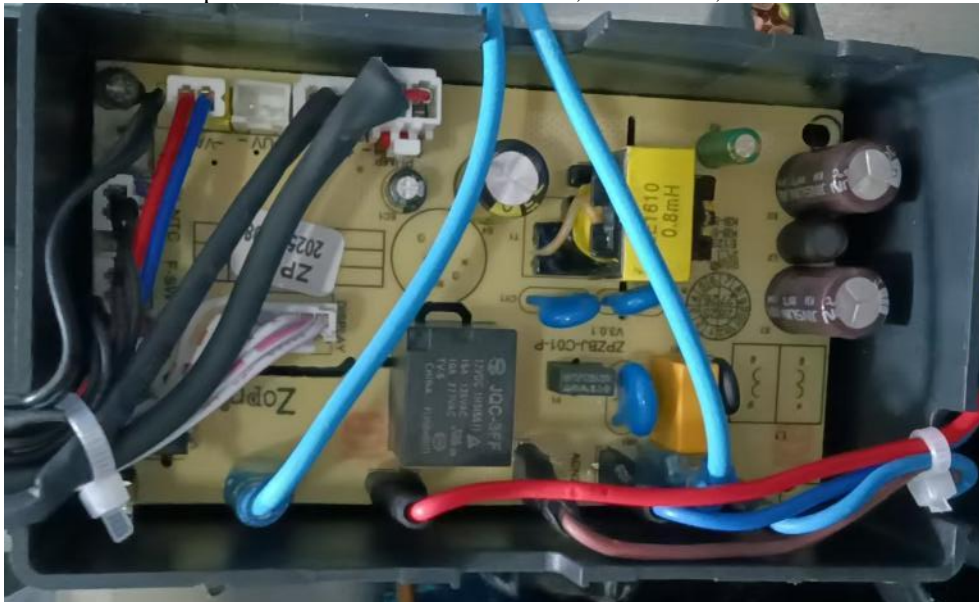

Photo 67

Description: Internal view of ZSW-ZB15, ZSW-ZB16, ZSW-ZB17

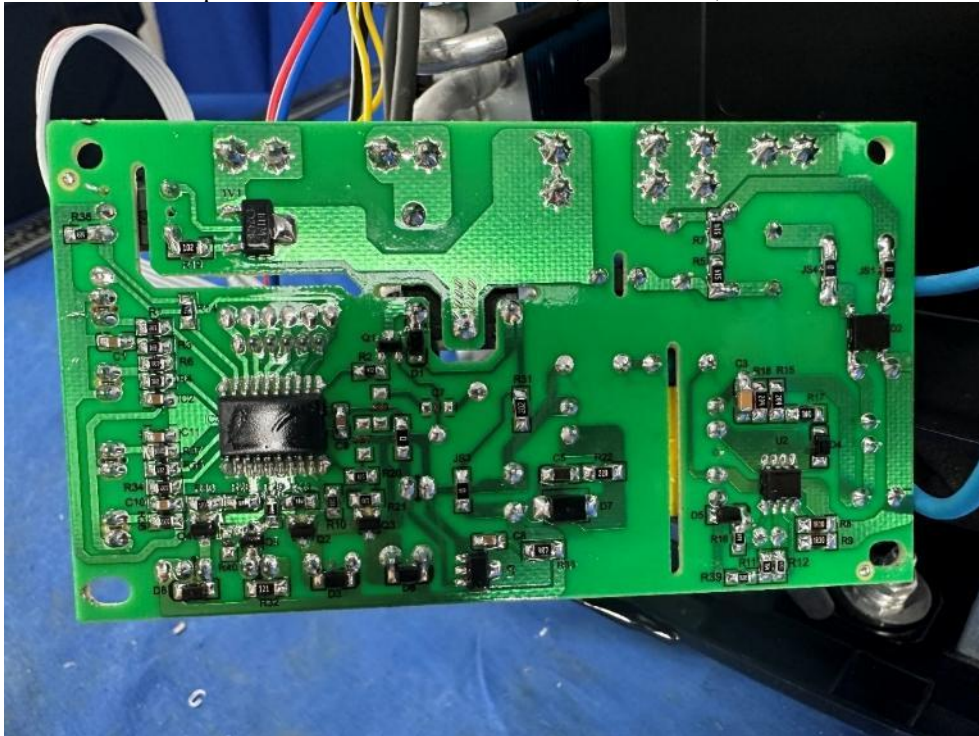

Photo 68

Description: Internal view of ZSW-ZB15



---

Test Report No.: EFSH25090011-IE-01-E01-A2

Eurofins Electrical Testing Service (Shanghai) Co., Ltd.  
Building 18, No.2168 Chenhang Highway, Minhang District, Shanghai, China

Photo 69

Description: Internal view of ZSW-ZB15



Photo 70

Description: Internal view of ZSW-ZB15

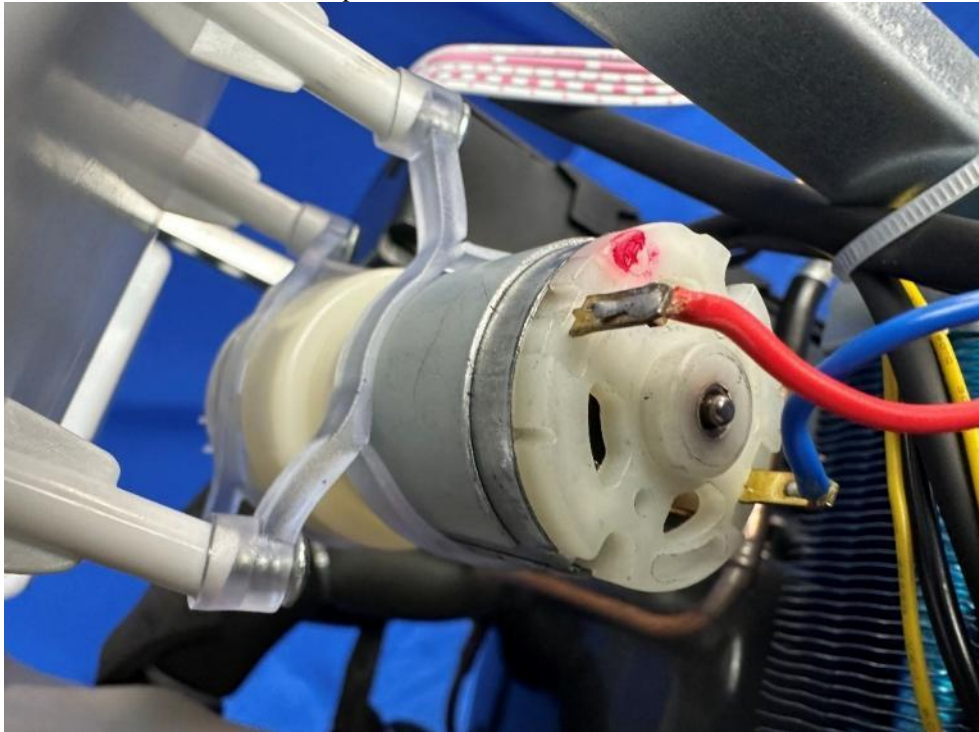

---

Test Report No.: EFSH25090011-IE-01-E01-A2

---

Eurofins Electrical Testing Service (Shanghai) Co., Ltd.  
Building 18, No.2168 Chenhang Highway, Minhang District, Shanghai, China

Photo 71

Description: Internal view of ZSW-ZB15



Photo 72

Description: Internal view of ZSW-ZB15



Test Report No.: EFSH25090011-IE-01-E01-A2

Eurofins Electrical Testing Service (Shanghai) Co., Ltd.  
Building 18, No.2168 Chenhang Highway, Minhang District, Shanghai, China

Photo 73

Description: Overall view of ZSW-ZB16

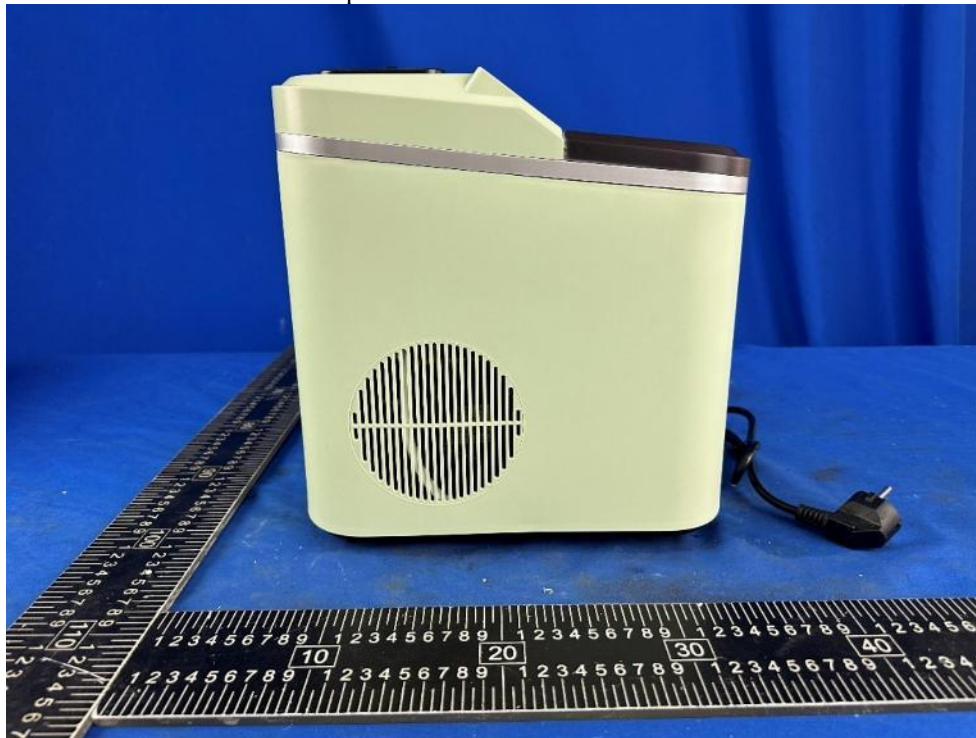

Photo 74

Description: Overall view of ZSW-ZB16

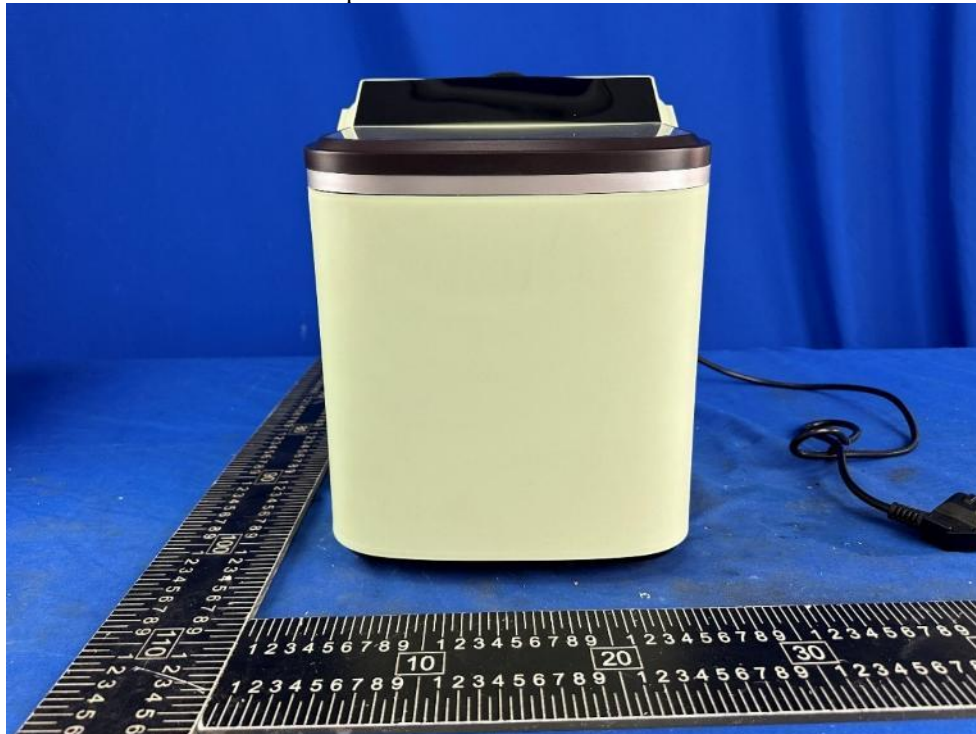

Photo 75

Description: Overall view of ZSW-ZB16

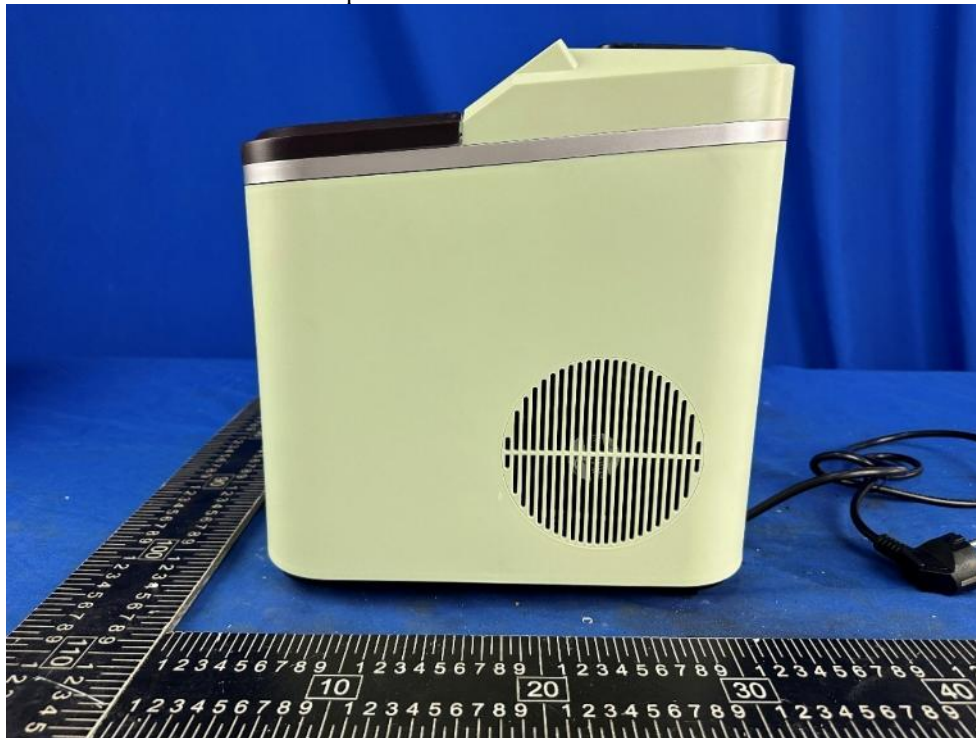

Photo 76

Description: Overall view of ZSW-ZB16



---

Test Report No.: EFSH25090011-IE-01-E01-A2

---

Eurofins Electrical Testing Service (Shanghai) Co., Ltd.  
Building 18, No.2168 Chenhang Highway, Minhang District, Shanghai, China

Photo 77

Description: Overall view of ZSW-ZB16



Photo 78

Description: Overall view of ZSW-ZB16

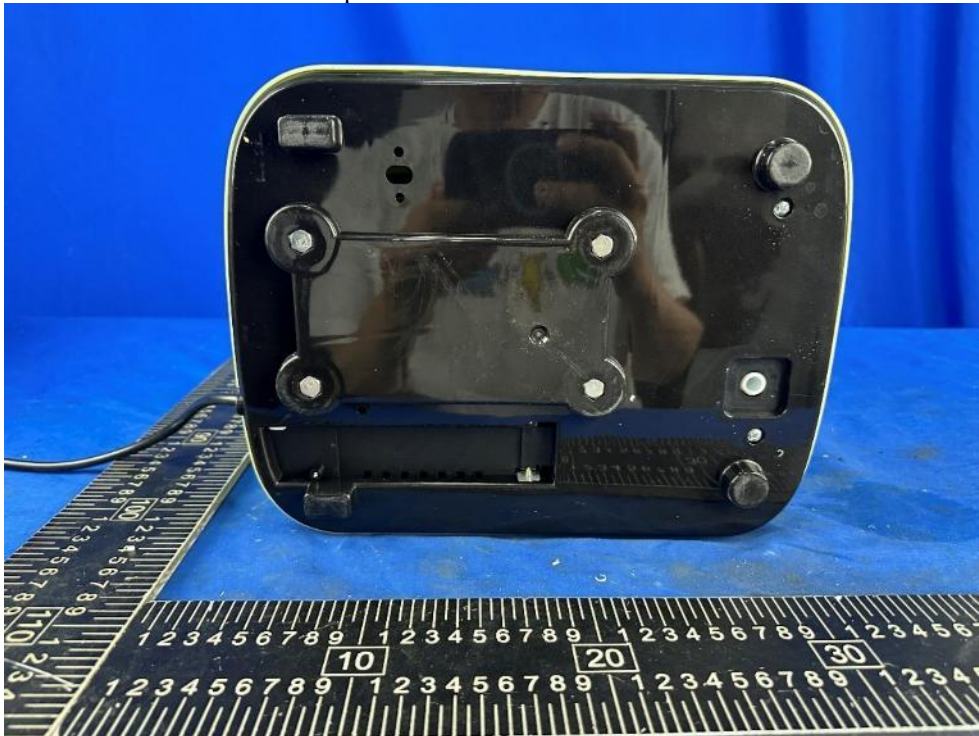

---

Test Report No.: EFSH25090011-IE-01-E01-A2

---

Eurofins Electrical Testing Service (Shanghai) Co., Ltd.  
Building 18, No.2168 Chenhang Highway, Minhang District, Shanghai, China

Photo 79

Description: Overall view of ZSW-ZB16



Photo 80

Description: Overall view of ZSW-ZB16



Photo 81

Description: Internal view of ZSW-ZB16



Photo 82

Description: Internal view of ZSW-ZB16

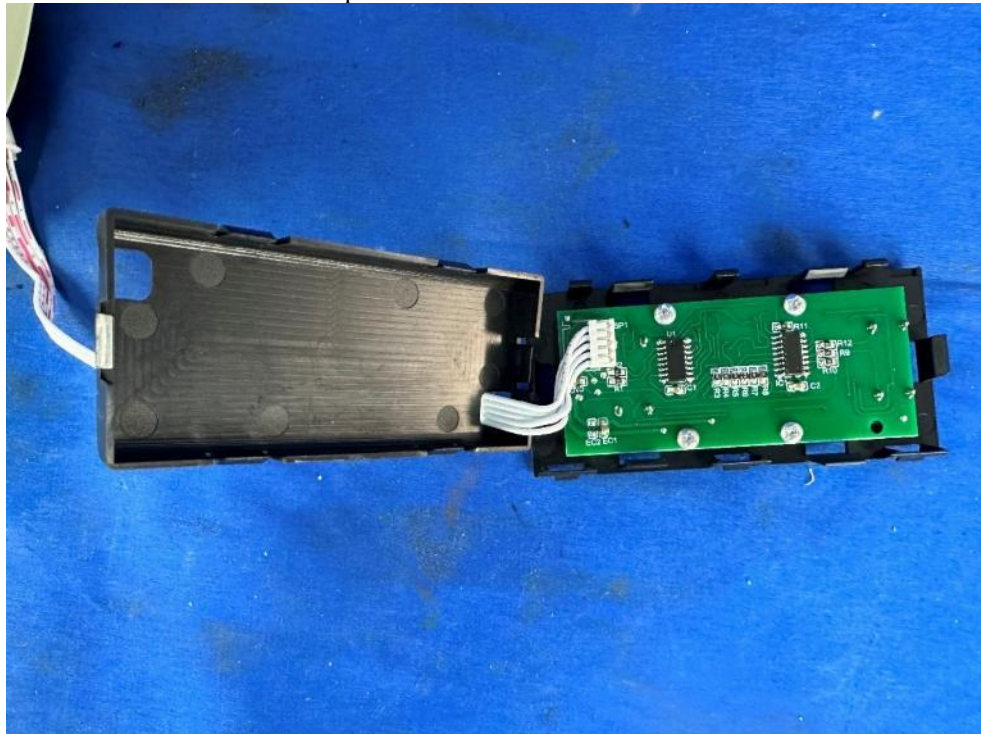

---

Test Report No.: EFSH25090011-IE-01-E01-A2

Eurofins Electrical Testing Service (Shanghai) Co., Ltd.  
Building 18, No.2168 Chenhang Highway, Minhang District, Shanghai, China

Photo 83

Description: Internal view of ZSW-ZB16

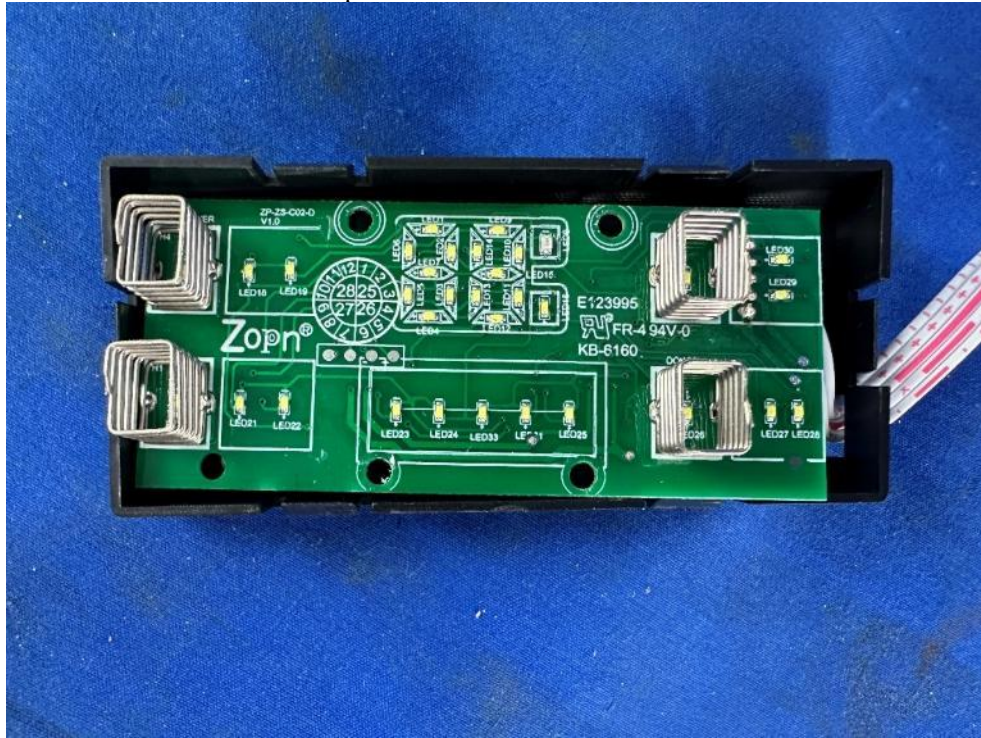

Photo 84

Description: Internal view of ZSW-ZB16

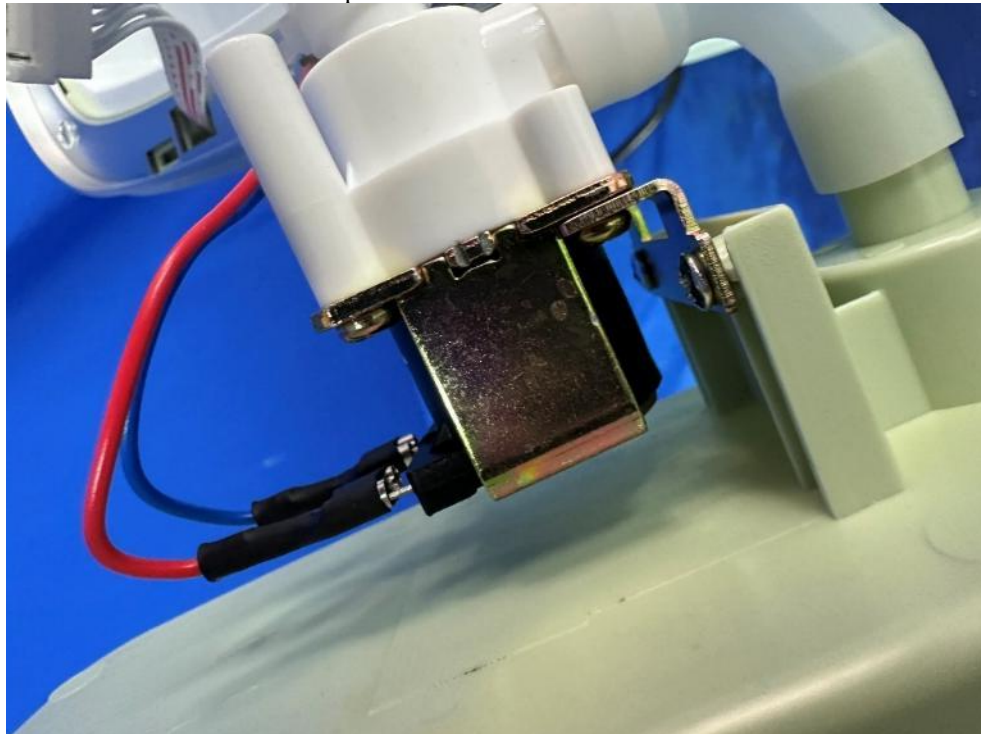

Photo 85

Description: Internal view of ZSW-ZB16



Photo 86

Description: Internal view of ZSW-ZB16

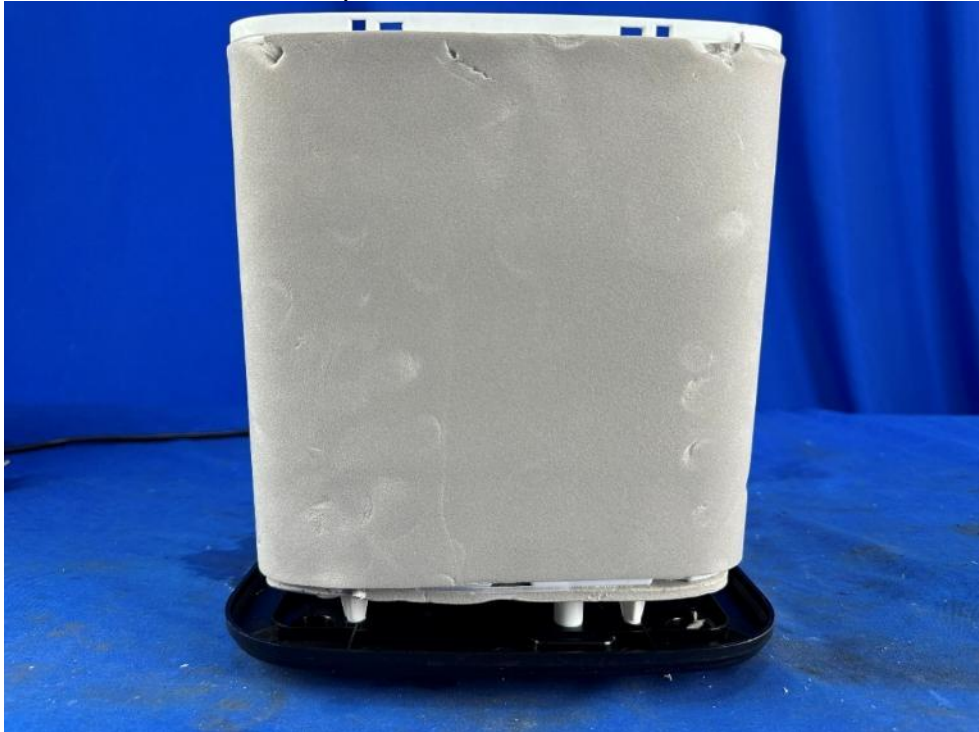

---

Test Report No.: EFSH25090011-IE-01-E01-A2

---

Eurofins Electrical Testing Service (Shanghai) Co., Ltd.  
Building 18, No.2168 Chenhang Highway, Minhang District, Shanghai, China

Photo 87

Description: Internal view of ZSW-ZB16



Photo 88

Description: Internal view of ZSW-ZB16



---

Test Report No.: EFSH25090011-IE-01-E01-A2

---

Eurofins Electrical Testing Service (Shanghai) Co., Ltd.  
Building 18, No.2168 Chenhang Highway, Minhang District, Shanghai, China

Photo 89

Description: Internal view of ZSW-ZB16



Photo 90

Description: Internal view of ZSW-ZB16

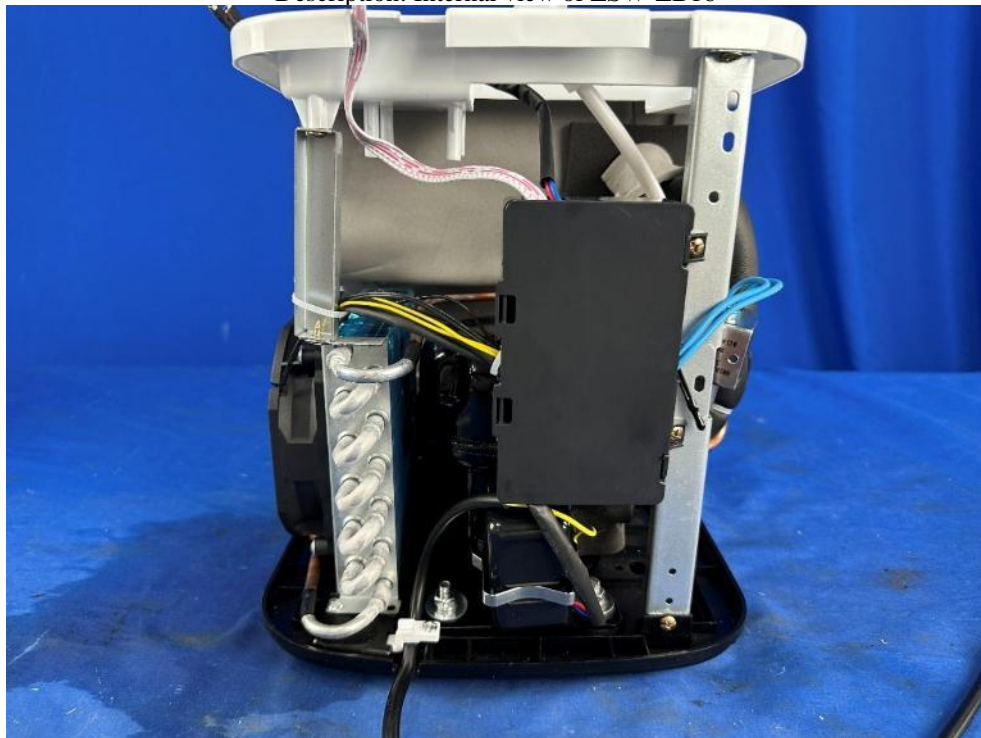

---

Test Report No.: EFSH25090011-IE-01-E01-A2

---

Eurofins Electrical Testing Service (Shanghai) Co., Ltd.  
Building 18, No.2168 Chenhang Highway, Minhang District, Shanghai, China

Photo 91

Description: Internal view of ZSW-ZB16



Photo 92

Description: Internal view of ZSW-ZB16



---

Test Report No.: EFSH25090011-IE-01-E01-A2

---

Eurofins Electrical Testing Service (Shanghai) Co., Ltd.  
Building 18, No.2168 Chenhang Highway, Minhang District, Shanghai, China

Photo 93

Description: Overall view of ZSW-ZB17



Photo 94

Description: Overall view of ZSW-ZB13 (white)



---

Test Report No.: EFSH25090011-IE-01-E01-A2

---

Eurofins Electrical Testing Service (Shanghai) Co., Ltd.  
Building 18, No.2168 Chenhang Highway, Minhang District, Shanghai, China

Photo 95

Description: Overall view of ZSW-ZB13 (Green)



Photo 96

Description: Overall view of ZSW-ZB13 (Gun grey)



Photo 97

Description: Overall view of ZSW-ZB14 (Green)



Photo 98

Description: Overall view of ZSW-ZB14 (Gun grey)



Photo 99

Description: Overall view of ZSW-ZB15 (Green)



Photo 100

Description: Overall view of ZSW-ZB15 (Gun grey)



Photo 101

Description: Overall view of ZSW-ZB16 (Gun grey)



Photo 102

Description: Overall view of ZSW-ZB16 (White)



---

Test Report No.: EFSH25090011-IE-01-E01-A2

---

Eurofins Electrical Testing Service (Shanghai) Co., Ltd.  
Building 18, No.2168 Chenhang Highway, Minhang District, Shanghai, China

Photo 103

Description: Overall view of ZSW-ZB17 (Gun grey)



Photo 104

Description: Overall view of ZSW-ZB17 (White)



---

Test Report No.: EFSH25090011-IE-01-E01-A2

---

Eurofins Electrical Testing Service (Shanghai) Co., Ltd.  
Building 18, No.2168 Chenhang Highway, Minhang District, Shanghai, China

Amendment 1

Description: Alternative main PCB view of ZSW-ZB13

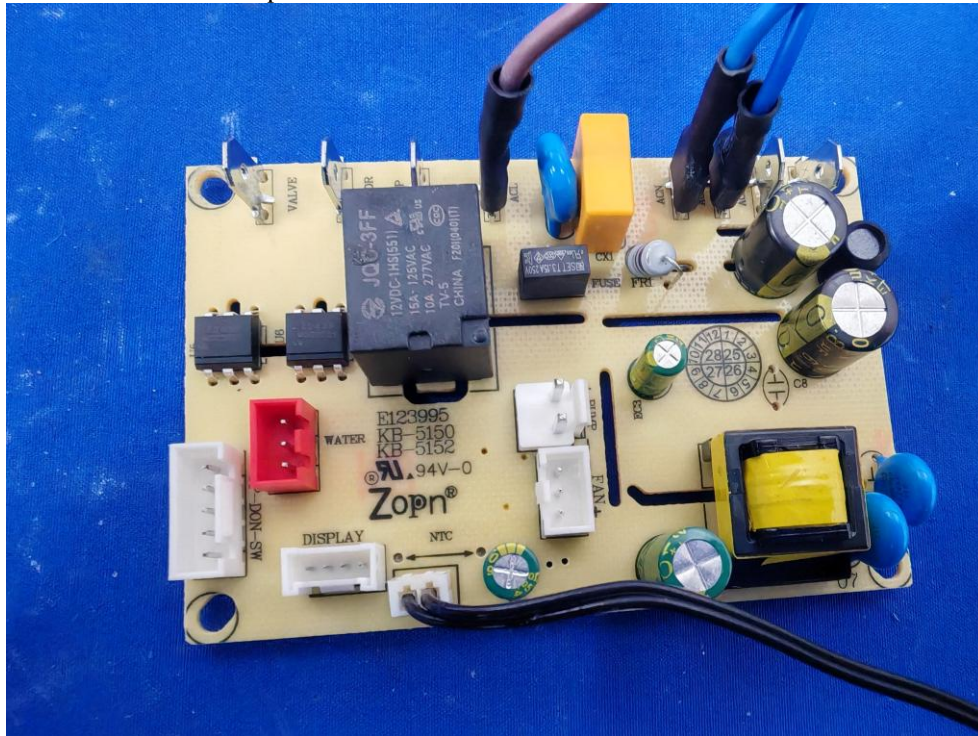

Description: Alternative main PCB view of ZSW-ZB13

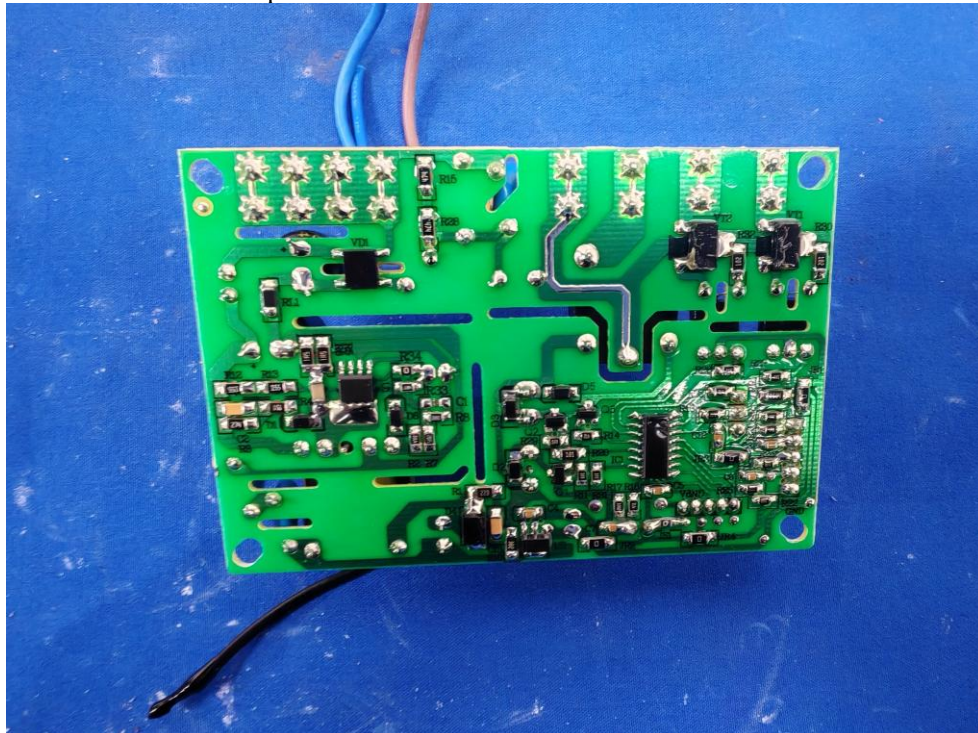

Description: Alternative synchronous motor view of ZSW-ZB13



Description: Alternative water pump view of ZSW-ZB13

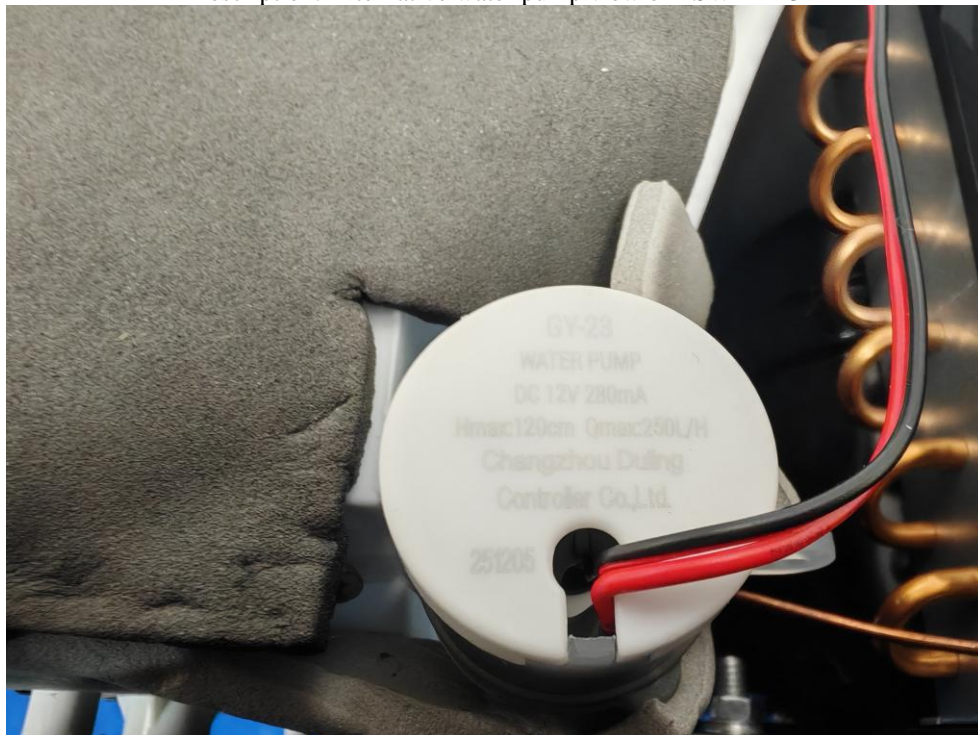

Test Report No.: EFSH25090011-IE-01-E01-A2

Eurofins Electrical Testing Service (Shanghai) Co., Ltd.  
Building 18, No.2168 Chenhang Highway, Minhang District, Shanghai, China

## 8 Amendment 1

The test report Ref. No. EFSH25090011-IE-01-E01 was modified on 2025-12-24 to include the following changes and/or additions:

1. Alternative main PCB, synchronous motor and water pump for ZSW-ZB13.

After review, ZSW-ZB13 with Alternative main PCB, synchronous motor and water pump was selected to full tests and recorded.

Test report ref. No. EFSH25090011-IE-01-E01 is replaced by this test report ref. No. EFSH25090011-IE-01-E01-A1.

## 9 Amendment 2

The test report Ref. No. EFSH25090011-IE-01-E01-A1 was modified on 2026-01-14 to include the following changes and/or additions:

1. The address of approval holder was modified.

After review, no additional test needs to be performed.

Test report ref. No. EFSH25090011-IE-01-E01 is replaced by this test report ref. No. EFSH25090011-IE-01-E01-A2.